

Bike-Lift

MOTORBIKE BOOK
2026

LEGENDA SIMBOLI

SYMBOL CHART



Logo che indica la tecnologia che a partire dal 2017 tutela la sicurezza dell'operatore. Uno speciale circuito interno trasforma la corrente 230V in arrivo in inoffensiva corrente 9V. Con questo innovativo step si eliminano i rischi di shock elettrico.

This logo indicates the technology developed since 2017 for the operator's safety. A special internal circuit transform the incoming 230V electricity into an harmless 9V DC electric tension. With this innovative technological step all risk of electric shock have been eliminated.



Logo che indica l'utilizzo di motori raffreddati da una ventola integrata. Con questo tipo di motore il gruppo della centralina/motore del sollevatore può operare anche a ritmi molto serrati senza per questo surriscaldare pericolosamente il motore. Studiato per i centri revisione.

This logo indicates the use of electrical motor cooled by a built-in fan. With this kind of motor the group power unit/motor can work continuously and at high external temperatures without taking the risk of dangerous over-heatings. Developed for the motorcycle review centers.



Logo che indica l'utilizzo del nuovo sistema di recupero olio in vigore dal 2019. Oltre ad aver dotato tutti i nostri cilindri di boccole auto-lubrificanti, una tubazione collega l'interno del cilindro con la centralina, consentendo ad eventuali gocce di olio di rimanere all'interno del circuito di lubrificazione e non cadere all'esterno.

This logo indicates the use of the new system of oil recovery and spill prevention, active since 2019. We have equipped our cylinders of self-lubricating bushings and also there is a drainpipe that connects the cylinder to the power unit, allowing eventual oil spill to remain inside the lubrication circuit and not drop out on the lift's basement.



Logo di prevenzione incidenti e uso non conforme dei cavalletti per moto. L'utilizzo dei cavalletti, sia anteriori che posteriori, è esclusivamente per uso statico, pertanto è proibito salire sulla moto quando sia posta sui cavalletti. E' altresì vietato accendere il motore e inserire una marcia anche se l'operatore non è sulla moto. Il mancato rispetto di queste raccomandazioni può essere causa di incidenti.

Accidents prevention logo that indicates a non-compliant use of our bike stands. The use of bike stands, front or rear they may be, it is exclusively for static purposes, therefore it is forbidden to ride the bike when the stands are in use. It is forbidden as well to switch on the engine and set a gear on, even if the operator is not riding the bike. Fail to follow these recommendations can be cause of accidents and serious injuries for the owner.

INDEX

SOLLEVATORI-LIFTS	5	MRA	60
WIDER 1000	7	MRF	60
ABSOLUTE 756 SPLIT	8	MRA-MXGP	61
ABSOLUTE 756 GATE	9	MRS-MOTO 3	61
ABSOLUTE 756 SPIDER	10	AL-BN	62
MAX TWIN ARMS 516	11	AL-DK	62
CUSTOM 500	12	AL-WT	63
MASTER 504	13	MF-SR	63
MAX GATE 516	14	CAVALLETTI - STANDS	65
MAX 516	15	BLACK ICE	66
SPORT GATE 500	16	CAVALLETTI ANTERIORI - FRONT STANDS	68
RACING 350	17	CAVALLETTI SOTTOCANOTTO - UNDERFORK	70
MONOLITH	18	CAVALLETTI POSTERIORI - REAR STANDS	72
VERSIONE DA INCASSO - FLOOR VERSION	19	CAVALLETTI MONOBRACCIO - SINGLE ARM	74
MORSE - WHEEL CLAMPS	23	CAVALLETTI POSTERIORI - REAR STANDS	76
GARDENING	27	CENTER STAND	80
GARDEN 1000	28	Paddock STANDS	81
GARDEN 754	29	ERGAL STANDS	82
FROG 500	30	OFFROAD STANDS	83
SOLLEVATORI CENTRALI - CENTRAL LIFTS	31	FLUO & COLORED COLLECTION	84
KODIAK 500	32	ATTREZZATURE PROFESSIONALI	
HQL 400	33	PROFESSIONAL EQUIPMENT	85
CFL-500 - CFL 500 Q	34	BIKE-21N	86
HXL 160	35	BIKE-35N	87
MCL	35	BIKE-SM	88
SVILUPPO OFFICINA - WORKSHOP BUILD-UP	36	ACCESSORIES - ACCESSORIES	90
MODOFLEX	38	BIKE-62N	92
SERIE-100 AP	39	BENCH MOTO MEC	93
SERIE-100	40	ACCESSORI - ACCESSORIES	94
MODULI - MODULES	42	BL-124-00	95
SCHEMA COMPOSIZIONE BANCHI		B-35N	96
WORKBENCHES COMPOSITION SCHEME	44	ACCESSORI - ACCESSORIES	97
PANNELLI DI CONGIUNZIONE / JUNCTION PANELS	45	ENGINE STAND	98
MF-SB 2300	46	SA-07	99
WOT-FOB-LAVABO	48	BL-4822331	99
MF-PW 1000-01	49	PRESSE - HYDRAULIC PRES	100
ARMADI - TOOL CABINETS	50	ATTREZZATURE - EQUIPMENT	101
COPERTURE IN GOMMA E ACCIAIO INOX - COVERS	51	RAMP-4000	103
PANNELLI PORTA ATTREZZI E PENSILI - WALL TOOLS	52	MORSE PER FURGONI E TRAILER - WHEEL CLAMPS	104
GANCI - HOOKS	53	ATTREZZI PROFESSIONALI -PROFESSIONAL TOOLS	105
HEXA	54	PULITORE FRENI E FRIZIONI - BREAKS CLEANER	106
SET DI ATTREZZI PER CASSETTIERE - TOOL KIT	56	ATTREZZI PROFESSIONALI -PROFESSIONAL TOOLS	107
RACING	59		



SOLLEVATORI
LIFTS



WIDER 1000



Patent N° 11183040.2



Torretta di controllo (di serie)
Control Panel (included)



Portata / Max Load Capacity	1000 Kg
Altezza Max / Max Height	130 cm
Altezza Min / Min Height	20 cm
Posizioni Sicura / Safety Position	11
Lunghezza / Length	230 cm
Dimensioni piano di sollevamento chiuso / Tabletop size closed	84x230 cm
Dimensioni piano di sollevamento aperto / Tabletop size open	150x230 cm
Dimensioni Binario / Ground rail size	40x150 cm
Dimensioni Rampa di salita / Run-up ramp size	82x40,5 cm
Ingombro totale sollevatore / Overall dimensions	240x100 cm
Peso / Weight	300 kg

WD-003 | Pompa Elettro Idraulica / Electro-Hydraulic Pump

Centralina Elettro-Idraulica Electro-Hydraulic Pump

Potenza / Power	1,1 Kw
Europa / Europe	230 Volts - 50 Hz

Su richiesta sono disponibili motorizzazioni per Giappone e America (US)
Engines for Japan and USA are available on request

Dotazione di serie Standard Equipment

Imballo / Packing	Cassa di legno / Wood box
Rampe / Run-up ramps	2 pcs
Feraruota / Wheel stop	2 pcs
Torretta / Tower Control	1 pcs
Binari / Railways	2 pcs

ABSOLUTE 756 SPLIT

Patent design N°2546986-0001



PZA

Placca di protezione
Chequerplate



Portata / Max Load Capacity	750 Kg
Altezza Max / Max Height	130 cm
Altezza Min / Min Height	20 cm
Posizioni Sicura / Safety Position	8
Dimensioni piano di sollevamento / Tabletop size	220x75 cm
Dimensioni Rampa di salita / Run-up ramp size	82x51 cm
Ingombro totale sollevatore / Overall dimensions	230x99 cm
Ingombro totale piano / Tabletop Overall dimensions	220x92 cm
Dimensioni Ali laterali / Side wings dimensions	161x8,5 cm
Dimensioni sportello gate / Sliding panel dimensions	60x36 cm
Dimensioni sportello split / Drop panel dimensions	75x44.5 cm
Peso / Weight	265 kg

AS756-003 | Pompa Elettro Idraulica / *Electro-Hydraulic Pump*

AS756-004/R | Pompa Elettro Idraulica comando remoto / *Electro-Hydraulic Pump w/remote*

AS756-003/F | Versione ad incasso a pavimento / *Floor version*

Centralina Elettro-Idraulica Electro-Hydraulic Pump

Potenza / Power	1,1 Kw
Europa / Europe	230 Volts - 50 Hz

Su richiesta sono disponibili motorizzazioni per Giappone e America (US)
Engines for Japan and USA are available on request

Dotazione di serie Standard Equipment

Scatola cartone con pallet in legno Cardboard with wooden crate	
Rampa / Run-up ramp	1 pc
Fermaruota / Wheel stop	1 pc
PZA	1 pc
Ali laterali / Side wings	2 pcs

ABSOLUTE 756 GATE

Patent design N°2546986-0001



PZA

Placca di protezione
Chequerplate



Portata / Max Load Capacity	750 Kg
Altezza Max / Max Height	130 cm
Altezza Min / Min Height	20 cm
Posizioni Sicura / Safety Position	8
Dimensioni piano di sollevamento / Tabletop size	220x75 cm
Dimensioni Rampa di salita / Run-up ramp size	82x51 cm
Ingombro totale sollevatore / Overall dimensions	230x99 cm
Ingombro totale piano / Tabletop Overall dimensions	220x92 cm
Dimensioni Ali laterali / Side wings dimensions	212x8,5 cm
Dimensioni sportello gate / Sliding panel dimensions	60x36 cm
Peso / Weight	280 kg

AG756-003 | Pompa Elettro Idraulica / *Electro-Hydraulic Pump*
AG756-004/R | Pompa Elettro Idraulica comando remoto / *Electro-Hydraulic Pump w/remote*
AG756-003/F | Versione ad incasso a pavimento / *Floor version*

Centralina Elettro-Idraulica Electro-Hydraulic Pump

Potenza / Power	1,1 Kw
Europa / Europe	230 Volts - 50 Hz

Su richiesta sono disponibili motorizzazioni per Giappone e America (US)
Engines for Japan and USA are available on request

Dotazione di serie Standard Equipment

Scatola cartone con pallet in legno Cardboard with wooden crate	
Rampa / Run-up ramp	1 pc
Fermaruota / Wheel stop	1 pc
PZA	1 pc
Ali laterali / Side wings	2 pcs

ABSOLUTE 756 SPIDER

Patent design N°2546986-0001



PZA

Placca di protezione
Chequerplate



Portata / Max Load Capacity	750 Kg
Altezza Max / Max Height	130 cm
Altezza Min / Min Height	20 cm
Posizioni Sicura / Safety Position	8
Dimensioni piano di sollevamento / Tabletop size	220x75 cm
Dimensioni Rampa di salita / Run-up ramp size	82x51 cm
Ingombro totale sollevatore / Overall dimensions	230x160 cm
Ingombro totale piano / Tabletop Overall dimensions	220x92 cm
Dimensioni Rampe di allargamento / Side run-up tool wings	23,5x82 cm
Peso / Weight	290 kg

SP756-003 | Pompa Elettro Idraulica / *Electro-Hydraulic Pump*

SP756-004/R | Pompa Elettro Idraulica comando remoto / *Electro-Hydraulic Pump w/remote*

Centralina Elettro-Idraulica
Electro-Hydraulic Pump

Potenza / Power	1,1 Kw
Europa / Europe	230 Volts - 50 Hz

Su richiesta sono disponibili motorizzazioni per Giappone e America (US)
Engines for Japan and USA are available on request

Dotazione di serie Standard Equipment

Scatola cartone con pallet in legno Cardboard with wooden crate	
Rampe / Run-up ramps	3 pcs
Fermaruota / Wheel stop	3 pcs
PZA	1 pc
Ali laterali / Side wings	2 pcs

MAX TWIN ARMS 516



W-36s
Morsa
Wheel Clamp

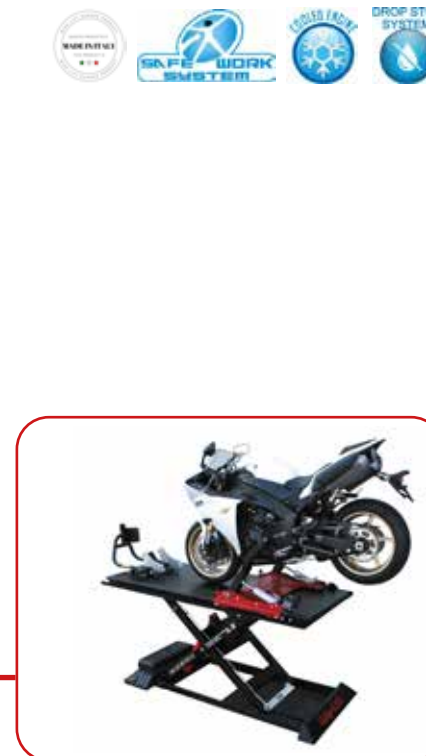

Portata / Max Load Capacity	500 Kg
Altezza Max / Max Height	120 cm
Altezza Min / Min Height	20 cm
Posizioni Sicura / Safety Position	8
Dimensioni piano di sollevamento / Tabeltop size	210x75 cm
Dimensioni Rampa di salita / Run-up ramp size	82x51 cm
Ingombro totale sollevatore / Overall dimensions	220x99 cm
Ingombro totale piano / Tabletop Overall dimensions	220x92 cm
Portata max bracci idraulici / Arms max load capacity	350kg
Altezza max bracci idraulici / Arms max height	60 cm
Altezza min bracci idraulici / Arms min height	22 cm
Peso / Weight	280 kg

MTA516-003 | Pompa Elettro Idraulica / *Electro-Hydraulic Pump*
MTA516-004/R | Pompa Elettro Idraulica comando remoto / *Electro-Hydraulic Pump w/remote*

Centralina Elettro-Idraulica Electro-Hydraulic Pump

Potenza / Power	1,1 Kw
Europa / Europe	230 Volts - 50 Hz

Su richiesta sono disponibili motorizzazioni per Giappone e America (US)
Engines for Japan and USA are available on request

Dotazione di serie Standard Equipment

Scatola cartone con pallet in legno Cardboard with wooden crate	
Rampa / Run-up ramp	1 pc
W-36s	1 pc
Supporti Pedane / Foot-peg supports	2 pcs
Cinghiette pedane / Short Tie-down	4 pcs
Cinghia automatica / Automatic Tie-down	1 pc
PZA	1 pc
Fermaruota / Wheel stop	1 pc

CUSTOM 500



PZA

Placca di protezione
Chequerplate



La torretta di controllo può essere
sostituita con il modulo comandi
M16 inserito nel banco di lavoro

*The central tower can be replaced
by a command module M16
fitted into the workbench*



Torretta di controllo (di serie)
Control Panel (included)

Portata / Max Load Capacity	500 Kg
Altezza Max / Max Height	110 cm
Altezza Min / Min Height	9 cm
Dimensioni piano di sollevamento / Tabetop size	220x80 cm
Dimensioni Rampa di salita mobile / Sliding Run-up ramp size	51,6x24 cm
Ingombro totale sollevatore / Overall dimensions	220x98 cm
Dimensioni ali laterali / Side wings dimensions	220x8,5 cm
Dimensioni sportello gate / Drop gate panel dimensions	60x28 cm
Peso / Weight	285 kg

CU500-003 | Pompa Elettro Idraulica / Electro-Hydraulic Pump

**Centralina Elettro-Idraulica
Electro-Hydraulic Pump**

Potenza / Power	1,1 Kw
Europa / Europe	230 Volts - 50 Hz

Su richiesta sono disponibili motorizzazioni per
Giappone e America (US)
Engines for Japan and USA are available on request

Dotazione di serie Standard Equipment

Scatola cartone con pallet in legno <i>Cardboard with wooden crate</i>	
Rampa / Run-up ramp	1 pc
PZA	1 pc
Ali laterali / Side wings	2 pcs
Fermaruota / Wheel stop	1 pc
Torretta / Tower control	1 pc

MASTER 504



PZA

Placca di protezione
Chequerplate



Portata / Max Load Capacity	500 Kg
Altezza Max / Max Height	130 cm
Altezza Min / Min Height	20 cm
Posizioni Sicura / Safety Position	8
Dimensioni piano di sollevamento / Tabletop size	210x75 cm
Dimensioni Rampa di salita mobile / Sliding Run-up ramp size	70x50 cm
Ingombro totale sollevatore / Overall dimensions	220x99 cm
Dimensioni ali laterali / Side wings dimensions	210x8,5 cm
Ingombro totale piano / Tabletop Overall dimensions	220x92 cm
Dimensioni sportello gate / Drop gate panel dimensions	60x36 cm
Peso / Weight	250 kg

MA504-003 | Pompa Elettro Idraulica / *Electro-Hydraulic Pump*

MA504-004/R | Pompa Elettro Idraulica comando remoto / *Electro-Hydraulic Pump w/remote*

Centralina Elettro-Idraulica Electro-Hydraulic Pump

Potenza / Power	1,1 Kw
Europa / Europe	230 Volts - 50 Hz

Su richiesta sono disponibili motorizzazioni per Giappone e America (US)
Engines for Japan and USA are available on request

Dotazione di serie Standard Equipment

Scatola cartone con pallet in legno Cardboard with wooden crate	
Rampa / Run-up ramp	1 pc
PZA	1 pc
Fermaruota / Wheel stop	1 pc
Ali laterali / Side wings	2 pcs

MAX GATE 516

PZA

Placca di protezione
Chequerplate



Portata / Max Load Capacity	500 Kg
Altezza Max / Max Height	120 cm
Altezza Min / Min Height	20 cm
Posizioni Sicura / Safety Position	8
Dimensioni piano di sollevamento / Tabletop size	210X75 cm
Dimensioni Rampa di salita mobile / Sliding Run-up ramp size	82x51 cm
Ingombro totale sollevatore / Overall dimensions	220x99 cm
Dimensioni ali laterali / Side wings dimensions	210x12 cm
Ingombro totale piano di sollevamento / Tabletop dimensions	210x99 cm
Dimensioni sportello gate / Drop gate panel dimensions	60x36 cm
Peso / Weight	235 kg

- MG516-001** | Pompa a pedale / Foot pump
- MG516-002** | Pompa ad aria / Air pump
- MG516-003** | Pompa Elettro Idraulica / Electro-Hydraulic Pump
- MG516-004/R** | Pompa Elettro Idraulica comando remoto / Electro-Hydraulic Pump w/remote
- MG516-003/F** | Versione da incasso a pavimento / Floor version

Centralina Elettro-Idraulica Electro-Hydraulic Pump

Potenza / Power	1,1 Kw
Europa / Europe	230 Volts - 50 Hz

Su richiesta sono disponibili motorizzazioni per Giappone e America (US)
Engines for Japan and USA are available on request

Pompa ad Aria / Air Pump

Pressione Aria / Air Pressure	7-10 bar
Consumo Aria / Air Consumption	300lt/min

Dotazione di serie Standard Equipment

Scatola cartone con pallet in legno Cardboard with wooden crate	
Rampa / Run-up ramp	1 pc
Fermaruota / Wheel stop	1 pc
PZA	1 pc
Ali laterali / Side wings	2 pcs

MAX 516



PZA

Placca di protezione
Chequerplate



PSW-516

Consiglio di utilizzo per questo modello:
Ali di allargamento (non incluse)
Working suggestion for this lift model:
Extension wings (not included)



Portata / Max Load Capacity	500 Kg
Altezza Max / Max Height	120 cm
Altezza Min / Min Height	20 cm
Posizioni Sicura / Safety Position	8
Dimensioni piano di sollevamento / Tabletop size	210X75 cm
Dimensioni Rampa di salita mobile / Sliding Run-up ramp size	82x51 cm
Ingombro totale sollevatore / Overall dimensions	220x99 cm
Dimensioni ali laterali / Side wings dimensions	210x12 cm
Ingombro totale piano di sollevamento / Tabletop dimensions	210x99 cm
Peso / Weight	235 kg

- M516-001 | Pompa a pedale / Foot pump
- M516-002 | Pompa ad aria / Air pump
- M516-003 | Pompa Elettro Idraulica / Electro-Hydraulic Pump
- M516-004/R | Pompa Elettro Idraulica comando remoto / Electro-Hydraulic Pump w/remote
- M516-003/F | Versione da incasso a pavimento / Floor version

Centralina Elettro-Idraulica Electro-Hydraulic Pump

Potenza / Power	1,1 Kw
Europa / Europe	230 Volts - 50 Hz

Su richiesta sono disponibili motorizzazioni per Giappone e America (US)
Engines for Japan and USA are available on request

Pompa ad Aria / Air Pump

Pressione Aria / Air Pressure	7-10 bar
Consumo Aria / Air Consumption	300lt/min

Dotazione di serie Standard Equipment

Scatola cartone con pallet in legno Cardboard with wooden crate	
Rampa / Run-up ramp	1 pc
Fermaruota / Wheel stop	1 pc
PZA	1 pc
Ali laterali / Side wings	2 pcs

SPORT GATE 500



PZA

Placca di protezione
Chequerplate



Portata / Max Load Capacity	500 Kg
Altezza Max / Max Height	120 cm
Altezza Min / Min Height	20 cm
Posizioni Sicura / Safety Position	8
Dimensioni piano di sollevamento / Tabletop size	210X60 cm
Dimensioni Rampa di salita mobile / Sliding Run-up ramp size	62x44,5 cm
Ingombro totale sollevatore / Overall dimensions	220x84 cm
Dimensioni ali laterali / Side wings dimensions	210x12 cm
Ingombro totale piano di sollevamento / Tabletop dimensions	210x84 cm
Dimensioni sportello gate / Drop gate panel dimensions	60x36 cm
Peso / Weight	200 kg

- SG-001 500** | Pompa a pedale / Foot pump
- SG-002 500** | Pompa ad aria / Air pump
- SG-003 500** | Pompa Elettro Idraulica / Electro-Hydraulic Pump
- SG-004/R 500** | Pompa Elettro Idraulica comando remoto / Electro-Hydraulic Pump w/remote
- SG-003/F 500** | Versione da incasso a pavimento / Floor version

Centralina Elettro-Idraulica Electro-Hydraulic Pump

Potenza / Power	1,1 Kw
Europa / Europe	230 Volts - 50 Hz

Su richiesta sono disponibili motorizzazioni per Giappone e America (US)
Engines for Japan and USA are available on request

Pompa ad Aria / Air Pump

Pressione Aria / Air Pressure	7-10 bar
Consumo Aria / Air Consumption	300lt/min

Dotazione di serie Standard Equipment

Scatola cartone con pallet in legno Cardboard with wooden crate	
Rampa / Run-up ramp	1 pc
Feraruota / Wheel stop	1 pc
PZA	1 pc
Ali laterali / Side wings	2 pcs

RACING 350



Portata / Max Load Capacity	350 Kg
Altezza Max / Max Height	120 cm
Altezza Min / Min Height	20 cm
Posizioni Sicura / Safety Position	8
Dimensioni piano di sollevamento / Tabletop size	200x60 cm
Dimensioni Rampa di salita mobile / Sliding Run-up ramp size	62x44,5 cm
Ingombro totale sollevatore / Overall dimensions	210x84 cm
Dimensioni ali laterali / Side wings dimensions	200x12 cm
Ingombro totale piano di sollevamento / Tabletop dimensions	200x84 cm
Peso / Weight	180 kg

- R-001 | Pompa a pedale / Foot pump
- R-002 | Pompa ad aria / Air pump
- R-003 | Pompa Elettro Idraulica / Electro-Hydraulic Pump
- R-004/R | Pompa Elettro Idraulica comando remoto / Electro-Hydraulic Pump w/remote
- R-003/F | Versione da incasso a pavimento / Floor version

Centralina Elettro-Idraulica Electro-Hydraulic Pump

Potenza / Power	1,1 Kw
Europa / Europe	230 Volts - 50 Hz

Su richiesta sono disponibili motorizzazioni per Giappone e America (US)
Engines for Japan and USA are available on request

Pompa ad Aria / Air Pump

Pressione Aria / Air Pressure	7-10 bar
Consumo Aria / Air Consumption	300lt/min

Dotazione di serie Standard Equipment

Scatola cartone con pallet in legno Cardboard with wooden crate	
Rampa / Run-up ramp	1 pc
Feraruota / Wheel stop	1 pc
Ali laterali / Side wings	2 pcs



MONOLITH



Morsa (optional)
Wheel Clamp (optional)

NEW
product
2026



Portata / Max Load Capacity	500 Kg
Altezza Max / Max Height	120 cm
Altezza Min / Min Height	18,2 cm
Posizioni Sicura / Safety Position	5
Dimensioni piano di sollevamento / Tabetop size	213X61 cm
Dimensioni Rampa di salita mobile / Sliding Run-up ramp size	73,5x30 cm
Peso / Weight	170 kg

MS-500 | Pompa Elettro Idraulica / Electro-Hydraulic Pump

Centralina Elettro-Idraulica
Electro-Hydraulic Pump

Potenza / Power	1,1 Kw
Europa / Europe	230 Volts - 50 Hz

Dotazione di serie **Standard Equipment**

Scatola cartone con pallet in legno Cardboard with wooden crate	
Rampa / Run-up ramps	1 pc
Feraruota / Wheel stop	1 pc
Ali laterali / Side wings	2 pcs

VERSIONE DA INCASSO



I modelli
ABSOLUTE SPLIT 756
ABSOLUTE GATE 756
MAX GATE 516
MAX 516
SPORT 500
RACING 350

sono disponibili anche nella versione da incasso nel pavimento.
Questa soluzione rende più agevole il posizionamento dei veicoli ed ottimizza l'utilizzo dello spazio interno dell'officina o dello show-room.

*Our lift models
ABSOLUTE SPLIT 756
ABSOLUTE GATE 756
MAX GATE 516
MAX 516
SPORT 500
RACING 350*

*are also available in the special floor version.
This solution makes the position of vehicles easier and optimizes the use of the workshop, showroom and space.*

Ali di allargamento
Extension side wings



SW-756 | Ali di allargamento
SW-756 | Extension side wings

Modello / Model **AG-756**
Dimensioni / Dimensions **27,5x212x60 cm**

SW-516 | Ali di allargamento
SW-516 | Extension side wings

Modello / Model **MG-516 / M516**
Dimensioni / Dimensions **27,5x210x50 cm**

Ali speciali pivottanti
Pivoting extension wings

PSW-516



Modello / Model **MG-516 / M516**
Dimensioni / Dimensions **27,5x210x50 cm**
Dotazione di serie **Standard Equipment**
Rampe / Run-up ramps **2 pc**
Fermaruota / Wheel stop **2 pc**
Ali fisse / Side fixed wings **4 pcs**
Ali mobili / Pivoting wings **2 pcs**

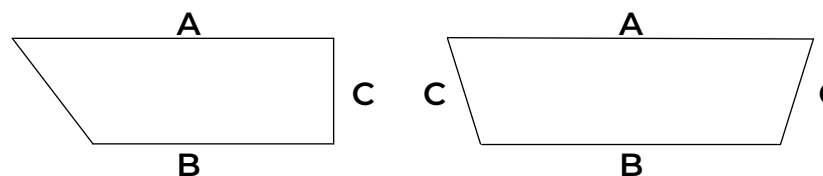

Ali fisse / Side fixed wings	
A	83 cm
B	52,5 cm
C	30 cm

Ali mobili / Pivoting wings	
A	104 cm
B	43 cm
C	30 cm

Adattatori in gomma
Rubber adapters



Codice Code	Dimensioni Dimensions
RA-20	140x120x20 mm
RA-40	140x120x40 mm
RA-60	140x120x60 mm

Guide scorrevoli
Extension side wings



Codice / Code Modello / Model

RAIL-350	R-350
RAIL-516	M516 / MG516 / SG-500/MA504
RAIL-CU	CU-500
RAIL-756	AG756
RAIL-756/S	AS756

Tappeti di protezione in gomma
Protection rubber mats



RM-SMALL

Codice / Code Dimensioni / Dimensions
RM-SMALL 50x16,5 cm

Estensioni laterali veicoli a 3 ruote
Side extensions for 3-wheeled vehicles



SW-SPIDER

Modello / Model AG756 / AS756

Dotazione di serie Standard Equipment

Rampe / Run-up ramps 2 pc

Fermaruota / Wheel stop 2 pc

Estensioni laterali / Side Extension 2 pcs

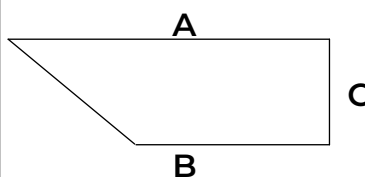

Dimensione / Dimensions	
A	104,5 cm
B	52 cm
C	43 cm

Rampa veicoli a 3 ruote
Run-up ramp for 3-wheeled vehicles



R-MP3

Modello / Model AG756 / MG516 / G754 / AS756/M516

Dimensioni / Dimensions 75x110 cm

Tappeti di protezione in gomma
Protection rubber mats



RM

Codice / Code Dimensioni / Dimensions
RM 33x44.5 cm

Piastra protezione anti-scivolo
Anti-skid protection plate



PZA



Modello / Model **tutti i sollevatori / all lifts**
Dimensioni / Dimensions **55x34 cm**

Pusalntiera con magnete
Hand control with magnet

HC



Kit telecomando remoto

Remote control kit

LC-005



Per sollevatori con CSP-04

For lifts with CSP-04

Pedaliera comandi sollevatore
Foot pedal control for lifts

FC/EL-CV



Pompa ad aria 200 bar
200 bar air pump

AP



Pompa a pedale
Foot pump

FP



MORSE
WHEEL CLAMPS

NEW
product
2025

W-42/N



*Regolabile
Automatica*

*ø Max Ruota
øWheel Max*

*ø Max Ruota
øWheel Max*

*Dimensioni
Dimensions*

Peso / Weight

*Adjustable
Automatic*

21"

12"

36x65x36 cm

12 kg

NEW
product
2026



W-40



*Regolabile
Manuale*

*Apertura massima
Max opening range*

*Apertura minima
Min opening range*

Peso / Weight

*Adjustable
Manual*

225 mm

60 mm

11 Kg



W-36S



<i>Automatica</i>	<i>Automatic</i>
<i>Apertura massima Max opening range</i>	<i>205 mm</i>
<i>Apertura minima Min opening range</i>	<i>70 mm</i>
<i>Peso / Weight</i>	<i>14 kg</i>

Dotata di sgancio rapido
Supplied with quick release

W-32N



<i>Pneumatica</i>	<i>Pneumatic</i>
<i>Apertura massima Max opening range</i>	<i>205 mm</i>
<i>Apertura minima Min opening range</i>	<i>55 mm</i>
<i>Peso / Weight</i>	<i>21 kg</i>

W-34N

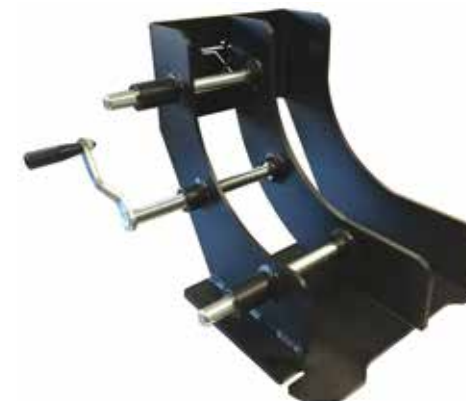

<i>Regolabile</i>	<i>Manual</i>
<i>Apertura massima Max opening range</i>	<i>210 mm</i>
<i>Apertura minima Min opening range</i>	<i>35 mm</i>
<i>Peso / Weight</i>	<i>16 kg</i>

Disponibile con kit sgancio rapido (optional)
Available with quick release kit (optional)

KIT SGANCIO RAPIDO





Bike-Lift

GARDENING

GARDEN 1000

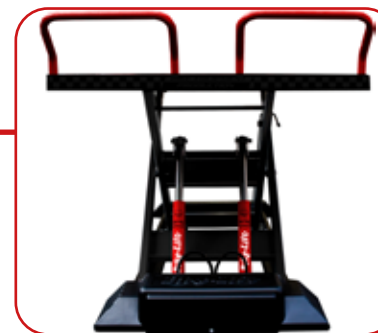

Portata / Max Load Capacity	1000 Kg
Altezza Max / Max Height	100 cm
Altezza Min / Min Height	20 cm
Posizioni Sicura / Safety Position	6
Dimensioni piano di sollevamento / Tabletop size	215x120 cm
Dimensioni Rampa di salita / Run-up ramp size	82x24 cm
Ingombro totale sollevatore / Overall dimensions	225x120 cm
Ingombro totale piano / Tabletop Overall dimensions	215x120 cm
Peso / Weight	300 kg

G-003/10 | Pompa Elettro Idraulica / *Electro-Hydraulic Pump*

G-004/10R | Pompa Elettro Idraulica comando remoto / *Electro-Hydraulic Pump w/remote*

Centralina Elettro-Idraulica Electro-Hydraulic Pump

Potenza / Power	1,1 Kw
Europa / Europe	230 Volts - 50 Hz

Su richiesta sono disponibili motorizzazioni per Giappone e America (US)
Engines for Japan and USA are available on request

Dotazione di serie Standard Equipment

Scatola cartone con pallet in legno Cardboard with wooden crate	
Rampe / Run-up ramps	2 pcs
Fermaruota / Wheel stop	2 pcs

GARDEN 754



Portata / Max Load Capacity	750 Kg
Altezza Max / Max Height	130 cm
Altezza Min / Min Height	20 cm
Posizioni Sicura / Safety Position	8
Dimensioni piano di sollevamento / Tabletop size	215x100 cm
Dimensioni Rampa di salita / Run-up ramp size	82x24 cm
Ingombro totale sollevatore / Overall dimensions	225x100 cm
Ingombro totale piano / Tabletop Overall dimensions	220x92 cm
Peso / Weight	280 kg

G-003 | Pompa Elettro Idraulica / *Electro-Hydraulic Pump*

G-004/R | Pompa Elettro Idraulica comando remoto / *Electro-Hydraulic Pump w/remote*

Centralina Elettro-Idraulica *Electro-Hydraulic Pump*

Potenza / Power	1,1 Kw
Europa / Europe	230 Volts - 50 Hz

Su richiesta sono disponibili motorizzazioni per Giappone e America (US)
Engines for Japan and USA are available on request

Dotazione di serie *Standard Equipment*

Scatola cartone con pallet in legno <i>Cardboard with wooden crate</i>	
Rampe / Run-up ramps	2 pcs
Fermaruota / Wheel stop	2 pcs

FROG 500

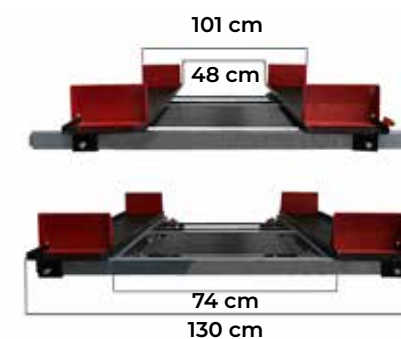

Portata / Max Load Capacity	500 Kg
Altezza Max (posizione orizzontale) / Max Height (horizontal)	80 cm
Altezza Min / Min Height	20 cm
Altezza Max (parte anteriore) / Front end max height	100 cm
Altezza Max (parte posteriore) / Rear end max height	155 cm
Posizioni Sicura / Safety Position	3
Dimensione Binario	200x26 cm
Distanza binari esterna Max-Min / Max-min external rails distance	130-101 cm
Distanza binari interna Max-Min / Max-min internal rails distance	74-48 cm
Dimensione rampe di salita / Run-up ramp dimensions	82x24 cm
Ingombro totale sollevatore / Overall dimensions	200x130 cm
Peso / Weight	285 kg

F500-003 | Pompa Elettro Idraulica / *Electro-Hydraulic Pump*

F500-004/R | Pompa Elettro Idraulica comando remoto / *Electro-Hydraulic Pump w/remote*

Centralina Elettro-Idraulica Electro-Hydraulic Pump

Potenza / Power	1,1 Kw
Europa / Europe	230 Volts - 50 Hz

Su richiesta sono disponibili motorizzazioni per Giappone e America (US)
Engines for Japan and USA are available on request

Dotazione di serie Standard Equipment

Cassa di legno Wooden box	
Rampe / Run-up ramps	2 pcs
Fermaruota / Wheel stop	4 pcs

SOLLEVATORI CENTRALI
CENTRAL LIFTS

KODIAK 500



Portata / Max Load Capacity	500 Kg
Altezza Max / Max Height	130 cm
Altezza Min / Min Height	20 cm
Posizioni Sicura / Safety position	11
Dimensioni piano di sollevamento / Tabetop size	45x33 cm
Ingombro totale sollevatore / Overall dimensions	190x78 cm
Peso / Weight	110 kg

- KD-001 | Pompa a pedale / Foot Pump
- KD-002 | Pompa ad Aria / Air Pump
- KD-003 | Pompa Elettro Idraulica / Electro-Hydraulic Pump
- KD-004/R | Pompa Elettro Idraulica comando remoto / Electro-Hydraulic Pump w/remote

Centralina Elettro-Idraulica Electro-Hydraulic Pump

Potenza / Power	1,1 Kw
Europa / Europe	230 Volts - 50 Hz

Su richiesta sono disponibili motorizzazioni per Giappone e America (US)
Engines for Japan and USA are available on request

Pompa ad Aria / Air Pump

Pressione Aria / Air Pressure	7-10 bar
Consumo Aria / Air Consumption	300lt/min

Dotazione di serie Standard Equipment

Scatola cartone con pallet in legno
Cardboard with wooden crate

HQL 400



Portata / Max Load Capacity	400 Kg
Altezza Max / Max Height	80 cm
Altezza Min / Min Height	23 cm
Posizioni Sicura / Safety position	5
Dimensioni piano di sollevamento / Tabetop size	53x36 cm
Ingombro totale versione 003 / Overall dimensions model 003	88x50 cm
Ingombro totale versione 001 / Overall dimensions model 001	78x50 cm
Dimensione appoggio gomma / Rubber mat size	45x33 cm
Peso / Weight	65 kg

HQL-001 | Pompa a pedale / Foot Pump

HQL-003 | Pompa Elettro Idraulica / Electro-Hydraulic Pump

Centralina Elettro-Idraulica Electro-Hydraulic Pump

Potenza / Power	1,1 Kw
Europa / Europe	230 Volts - 50 Hz

Su richiesta sono disponibili motorizzazioni per Giappone e America (US)
Engines for Japan and USA are available on request

Dotazione di serie Standard Equipment

Scatola cartone con pallet in legno Cardboard with wooden crate	
Maniglia di trasporto / Transport handle	1 pc
Tappeto gomma / Rubber Mat	1 pc

CFL-500



CFL-500/Q



Versione custom & cruiser Custom & cruiser version	
Codice / Code	CFL-500
Portata / Max Load Capacity	500 Kg
Pompa a pedale / Foot pump	
Posizioni Sicura / Safety position	3
Larghezza / Width	38 cm
Altezza massima / Max height	45 cm
Altezza minima / Min height	11 cm
Peso / Weight	25 kg

Versione quad & ATV ATV & quad version	
Codice / Code	CFL-500/Q
Portata / Max Load Capacity	500 Kg
Pompa a pedale / Foot pump	
Posizioni Sicura / Safety position	3
Larghezza / Width	38 cm
Altezza massima / Max height	55 cm
Altezza minima / Min height	21 cm
Peso / Weight	25 kg

HXL 160



Codice / Code	HXL-160
Portata / Max Load Capacity	160 Kg
Pompa a pedale / Foot pump	
Posizioni Sicura / Safety position	4
Larghezza / Width	33x45 cm
Altezza massima / Max height	89 cm
Altezza minima / Min height	39 cm
Molle di sicurezza / Safety hooks	2 pcs
Peso / Weight	39 kg

MCL

MCL-20



Perno di sicurezza
regolabile in 9 posizioni
Safety pin
adjustable in 9 positions



MCL-03A

Supporti per MCL-20 da utilizzare con moto che necessitano di essere alzate dalla parte inferiore del telaio

Optional adapters for MCL-20 to be used to lift the vehicle from the bottom part of the frame.



MCL-30



Codice / Code	MCL-20
Portata / Max Load Capacity	500 Kg
Manuale / Manual	
Larghezza / Width	15 cm
Altezza massima / Max height	35 cm
Altezza minima / Min height	8,5 cm
Lunghezza / Length	40 cm
Peso / Weight	11 kg

Codice / Code	MCL-30
Portata / Max Load Capacity	500 Kg
Manuale / Manual	
Larghezza / Width	25 cm
Altezza massima / Max height	35 cm
Altezza minima / Min height	8,5 cm
Lunghezza / Length	40 cm
Peso / Weight	13 kg



SVILUPPO OFFICINA WORKSHOP BUILD-UP

Bike-Lift Europe fornisce ai propri clienti un servizio professionale nella realizzazione della propria officina, sia di nuovo allestimento che di riammodernamento. Quando si decide di aprire un'officina moto, o semplicemente di rinnovare il proprio luogo di lavoro, è necessario avvalersi di un partner che possa garantire un servizio a 360°, affiancando il cliente non solo nella fornitura dei migliori materiali ma anche nella realizzazione e studio del progetto, affinché sia il più funzionale possibile. Un team di esperti della Bike-Lift Europe, dopo un primo sopralluogo dei locali ed un approfondito colloquio con il cliente, in cui verranno fissate le esigenze di tipo logistico e lavorativo (target, volume di lavoro, numero postazioni, tipologia di interventi sui veicoli etc.) dell'officina, svilupperà un progetto finalizzato al miglior allestimento possibile, in termini di efficacia ed efficienza. Il valore aggiunto che Bike-lift Europe offre ai propri clienti è quello di trovare in un unico interlocutore la competenza e professionalità mirate a poter garantire soluzioni idonee alla propria tipologia di lavoro, sfruttando al meglio lo spazio disponibile e garantendo un servizio studiato ad-hoc.

Bike-Lift Europe offers to its customers a professional service about the realization of the workshop, a new one or a refurbishing of an existing one.

When you decide to open a motorcycle workshop or just renovate your workplace, it is important to rely on a partner that can ensure an all-round service and support the client not only by supplying the best materials but also implementing the project.

A Bike-Lift Europe team of experts will visit the premises and talk to the customer to pin-point logistic and work requirements (target, volume of work, number of bays, type of interventions on the vehicles etc.) and develop the project in order to obtain the best result possible in terms of effectiveness and efficiency.

Bike-Lift Europe's added value is about providing a single interface to the customer that can ensure the best solution to meet all requirements, making use of all the available space and guaranteeing a tailor-made service that stands out for professionalism.

MODD**O**Produced by **Bike-Lift****FLEX**



SERIE-100

Supporti Auto Portanti

Self standing supports

MF-BL H100-AP



Codice / Code	Dimensioni / Dimensions
MF-BL H100 AP - 1000	1000x800x2000H mm
MF-BL H100 AP - 1620	1620x800x2000H mm
MF-BL H100 AP - 2000	2000x800x2000H mm



SERIE-100

Banchi e Moduli

Workbenches & Modules

MF-BL 2000-01M



MF-BL 2000-01V



MF-BL 2000-03



MF-BL 2000-01V-L2



Codice / Code	MF-BL 2000-01M	MF-BL 2000-01V
Versione / Version	Moduli / Modules	Ripiano / Shelf
Spazio interno / Internal space	1750x695 mm	1750x695 mm
Dimensioni / Dimensions	2000x800x1000H mm	2000x800x1000H mm

Codice / Code	MF-BL 2000-03	MF-BL 2000-01V-L2
Versione / Version	Ripiano e Modulo Shelf and Module	Doppio ripiano Double Shelf
Spazio interno / Internal space	1060x695 mm	1750x695 mm
Dimensioni / Dimensions	2000x800x1000H mm	2000x800x1000H mm

Banco per carrello (non incluso)

Workbench for drawer cabin (not included)



Codice / Code	Dimensioni / Dimensions
MF-BL 2000-01MC	2000x800x1000H mm
MF-BL 1620-01MC	1620x800x1000H mm
MF-BL 1000-01MC	1000x800x1000H mm

Piano ad angolo

Corner shelf



Codice / Code	Dimensioni / Dimensions
MF-PANG-900	900x900 mm

Banco a penisola

T-shaped workbench

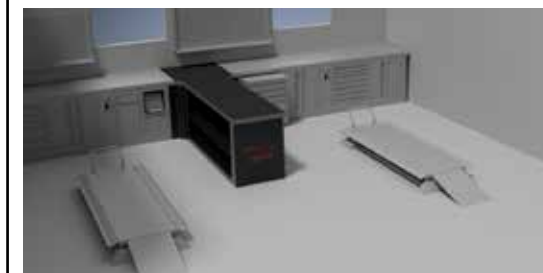

Codice / Code	Dimensioni / Dimensions
MF-BL 2000 PE	2900x800x1000H mm

SERIE-100

Banchi e Moduli

Workbenches & Modules

MF-BL 1620-01M



MF-BL 1620-01V



MF-BL 1620-03



MF-BL 1620-01V-L2



Codice / Code	MF-BL 1620-01M	MF-BL 1620-01V
Versione / Version	Moduli / Modules	Ripiano / Shelf
Spazio interno / Internal space	1375x695 mm	1375x695 mm
Dimensioni / Dimensions	1620x800x1000H mm	1620x800x1000H mm

Codice / Code	MF-BL 1620-03	MF-BL 1620-01V-L2
Versione / Version	Ripiano e Modulo Shelf and Module	Doppio ripiano Double Shelf
Spazio interno / Internal space	685x695 mm	1375x695 mm
Dimensioni / Dimensions	1620x800x1000H mm	1620x800x1000H mm

SERIE-100

Banchi e Moduli

Workbenches & Modules

MF-BL 1000-01M



MF-BL 1000-01V



MF-BL 1000-01V-L2



Codice / Code	MF-BL 1000-01M	MF-BL 1000-01V	MF-BL 1000-01V-L2
Versione / Version	Moduli / Modules	Ripiano / Shelf	Doppio ripiano Double Shelf
Spazio interno / Internal space	760x695 mm	760x695 mm	760x695 mm
Dimensioni / Dimensions	1000x800x1000H mm	1000x800x1000H mm	1000x800x1000H mm

MODULI



Modulo con ruote
5 cassetti
*5 drawers module
with casters*



Codice / Code **MF-BL CB**

Carrello con 3 ripiani
3 shelves trolley



Codice / Code **MF-BL CB3**

Modulo con 7 cassetti
7 drawers module



Codice / Code **MF-BL M1**

Modulo 5 cassetti
5 drawers module



Codice / Code **MF-BL M2**

Modulo 5 cassetti larghi
5 wide drawers module



Codice / Code **MF-BL M12**

Modulo piccolo 6 cassetti
*Small module
with 6 casters*



Codice / Code **MF-BL M13**

Modulo con sportello
da 380 o 310 mm
*380 or 310 mm module
with door*



Codice / Code **MF-BL M3**
Codice / Code **MF-BL M3P**

Modulo bidone rifiuti
Litter module



Codice / Code **MF-BL M4**

Modulo bidone
rifiuti doppio
Wide litter module



Codice / Code **MF-BL M4XL**

Modulo con ripiano
Module with shelf



Codice / Code **MF-BL M5**



MODULI

Moduli con rotolo di carta
da 380 o 310 mm
*380 or 310mm module with
paper roller*



Codice / Code	MF-BL M6
Codice / Code	MF-BL M6P

Modulo con pistola e
arrotolatore olio 10mt
*Module with oil gun and
hose reel 10mts*



Codice / Code	MF-BL M7
---------------	-----------------

Modulo con 2 pistole e 2
arrotolatori olio 10mt
*Module with 2 oil guns
and 2 hose reels 10mts*



Codice / Code	MF-BL M77
---------------	------------------

Modulo con 3 pistole e 3
arrotolatori olio 10mt
*Module with 3 oil guns
and 3 hose reels 10mts*



Codice / Code	MF-BL M777
---------------	-------------------

Modulo comandi per
CUSTOM - WIDER
*CUSTOM and WIDER lift
control module*



Codice / Code	MF-BL M16
---------------	------------------

Modulo doppia porta con
ripiano
*Double door and shelf
module*



Codice / Code	MF-BL M10
---------------	------------------

Modulo con presa schuko
e arrotolatore aria 10mt
*Module with german
socket and 10mts air hose*



Codice / Code	MF-BL M8
---------------	-----------------

Modulo largo con ripiano e
2 sportelli
*Wide module with 2 doors
and shelf*



Codice / Code	MF-BL M9
---------------	-----------------

Modulo con morsa a scomparsa

Module with clamp

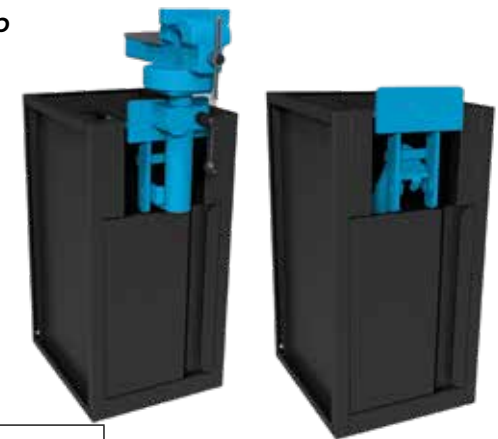

Codice / Code	MF-BL M19
---------------	------------------

SCHEMA COMPOSIZIONE BANCHI WORKBENCHES COMPOSITION SCHEME

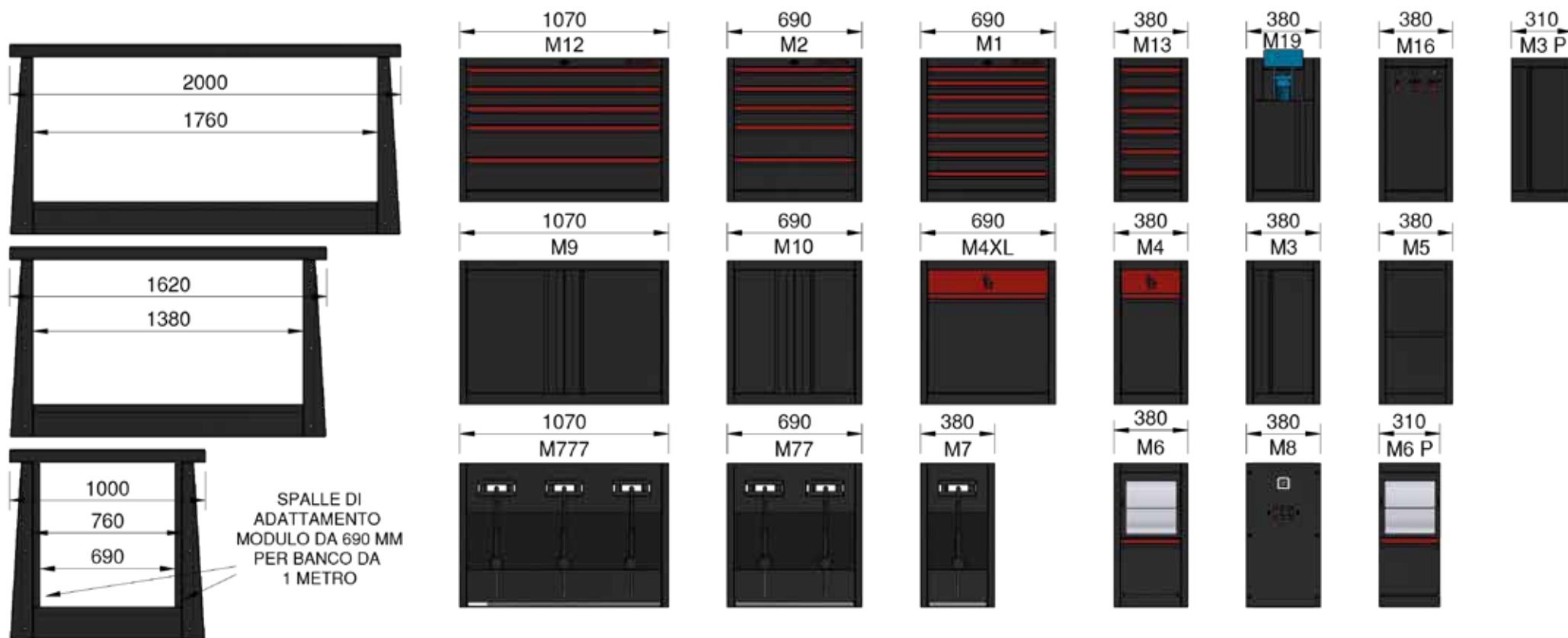

PANNELLI DI CONGIUNZIONE / JUNCTION



Pannello unione banchi con logo
Connection panel with logo



Codice / Code **MF-PU-U**

Pannello angolare unione banchi
Corner connection panel



Codice / Code **MF-PU-A**

Pannello unione banchi con arrotolatore aria 10mt e presa di corrente (inclusi)
Connection panel with 10mt air hose and electric plug (included)



Codice / Code **MF-PU-AE**

Pannello angolare unione banchi con presa di corrente e arrotolatore aria 10mt (inclusi)
Corner connection panel with electric plug and 10mt air hose (included)



Codice / Code **MF-PU-AEA**

Pannello unione banchi con tre prese schuko
Connection panel with triple schuko plugs



Codice / Code **MF-PU-E3**

Pannello unione banchi doppio arrotolatore aria e elettrico
Connection panel with double air hose and electric reel



Codice / Code **MF-PU-AE2**

Pannello angolare unione banchi con doppio arrotolatore aria e elettrico
Corner connection panel with 10mt air hose and 15mt electric cable



Codice / Code **MF-PU-AEA2**

Pannello unione banchi con presa Schuko, attacco lan e arrotolatore aria 10mt (inclusi)
Connection panel with german plug, lan cable and 10mt air hose (included)



Codice / Code **MF-PU-ASL**

Pannello unione banchi con presa Schuko e arrotolatore elettrico 10mt con presa (inclusi)
Connection panel with german plug, and 10mt electric cable (included)



Codice / Code **MF-PU-EE**

Pannello angolare con presa Schuko e arrotolatore elettrico 10mt con presa (inclusi)
Corner connection panel with german plug, and 10mt electric cable (included)



Codice / Code **MF-PU-AEE**

MODOFLEX

Produced by **Bike-Lift**

MF-SB 2300

46

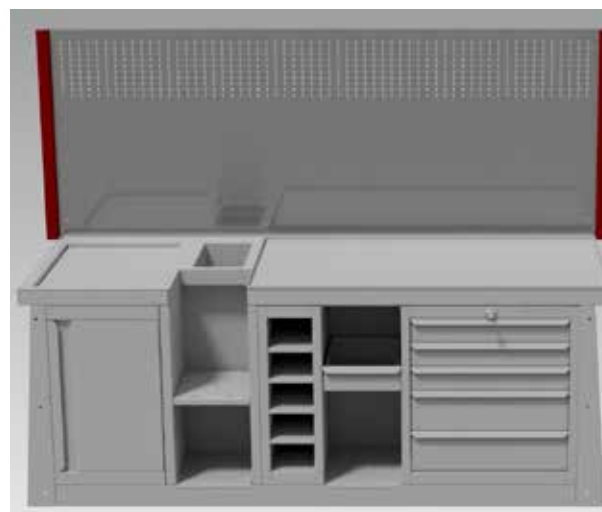

OPTIONAL
Gancio per steli
forcelle

OPTIONAL
Hook clip for gfork
cartridges



Codice / Code **GSF**

Banco manutenzione sospensioni <i>Suspension repair workbench</i>	
Codice / Code	MF-SB 2300
Dimensioni /Dimensions	2300x800x1000 mm
Peso / Weight	350 kg

Banco professionale per la manutenzione e riparazione delle sospensioni, con piani di lavoro, griglie e vasche di scolo olio in acciaio inox. Fornito di una cassettera a 5 cassetti e di un modulo per la sistemazione delle cartucce di ricambio per gli steli; con 1 morsa incluse e con 6 piedini regolabili.

Professional suspension bench, with tabletop, grids and oil drain basins all made in stainless steel. This product features a 5 drawer cabinet and a module for storing the spare fork cartridges. It is supplied with 1 vice included and 6 adjustable foot.

Codice / Code	MF-BL KGP/SS
Dimensioni /Dimensions	2300x900 mm
Peso / Weight	15 kg

Griglia in acciaio inox con piantoni di sostegno da posizionare in corrispondenza del banco sospensioni per poter appendere gli steli smontati.

Utilizzando l'apposita griglia da 10cm fra il banco ed il muro si raccolgono gli eventuali liquidi.

Stainless steel wall grid board with side supports to be positioned at the workbench wall and hang the disassembled forks and suspension using the special 10cm wide grid included in the workbench, to drain the eventual liquids.

MF-SB 2300

OPTIONAL
Vaschetta plastica
per cassetto

OPTIONAL
Waste oil tank for drawer



Codice / Code **ECO-TBS**

OPTIONAL
Vasca per raccolta olio
esausto con ruote 36lt

OPTIONAL
36lt waste oil tank with
wheels



Codice / Code **ECO-T36**

Vasca inox
con griglia
rimovibile
*Stainless Steel
basin with
removable
grid cover*

Pozzetto in acciaio inox
per pezzi alti con griglia
rimovibile

*Stainless Steel deep
basin for long parts with
removable grid*

Piano in acciaio
inox per lo
smontaggio
delle forcelle e
delle sospensioni

*Stainless Steel
tabletop for the
disassembling of
forks and
suspension*

Cassettiera a 5
cassetti per attrezzi

*5 drawers cabinet
for tools*

Cassetto scorrevole per
vaschetta in plastica
(non incl.) per la raccolta
dell'olio durante lo
smontaggio
degli steli

*Sliding drawer for a
plastic pan (not incl.) for
the containment of the
oil during the cartridges
disassembling*

Sportello per
accesso al
contenitore di
raccolta olio
(non incluso)

*Access door to the
waste oil container
(not included)*

Attacco morsa basso per
lavori sulla parte alta della
sospensione

*Low vice fitting for
operations in the high
side of the suspension*

Morsa inclusa
Wheel Clamp
included

Morsa non
inclusa
Wheel Clamp
not included

Vano di servizio per
componenti
*Components open
shelf*

Griglia con larghezza di 10
centimetri per la raccolta di
liquidi durante l'asciugatura
da usare in combinazione alla
griglia in acciaio inox da muro.

*10 cm wide stainless steel
grid for the drain of liquids of
forks repaired. To be
use together the stainless
steel wall grid board.*

Ripiani per le
cartucce nuove
degli steli

*Trays for the
spare
fork cartridges*

OPTIONAL
Morsa in acciaio 125mm

OPTIONAL
125mm steel vice

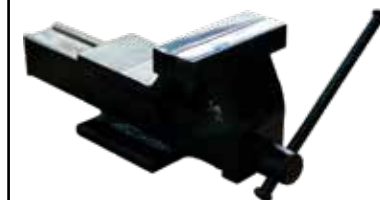

Codice / Code **BL-33700125**



WOT-FOB-LAVABO



Modulo con vasca in acciaio e pompa di aspirazione olio esausto.
Vasca di raccolta all'interno del modulo.

Module with stainless steel basin and suction pump for the waste oil. Drain tank inside the module.



Codice / Code

MF-WOT

Modulo con vasca in acciaio senza pompa di aspirazione (a gravità) per olio esausto forcelle. Vasca di raccolta all'interno del modulo. (non inclusa)

Module with stainless steel basin and suction pump for the waste fork oil. Drain tank inside the module. (not included)



Codice / Code

MF-FOB

Modulo con lavandino in acciaio inox e copertura ribaltabile. Attacchi compresi nel rubinetto

Module with stainless steel basin and tilting cover panel. Water line connection included



Codice / Code

MF-BL M18

MF-PW 1000-01



Materiale
Material
LDPE



Dispositivo ad alta visione permette una visuale ottimale durante le operazioni di pulizia ad alta pressione solamente con l'ausilio dell'aria compressa a 2,5bar

High vision device allows an optimal view during high pressure cleaning operations only with the aid of compressed air at 2.5 bar

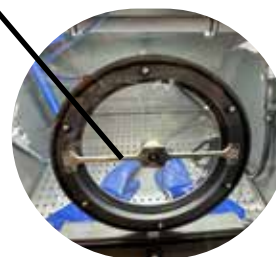

Codice	Code	MF-PW 1000-01
Dimensioni	Dimensions	1150x835 mm
Dimensioni piano di lavoro	Working space dimensions	840x600 mm
Temperatura standard	Standard temperature	35°
Potenza riscaldamento	Heat power	800 W
Potenza pompa liquida (LP)	(LP) Liquid pump pressure	45 W
Potenza Alta pressione (HP)	High pressure power	2,2 Kw
Pressione max. alta pressione	Max pressure high pressure	90 bar
Rumorosità alta pressione	High pressure noise	85 dBa
Capacità carico MC-HP	MC-HP capacity	100lt
Capacità lavoro minima	Minimum working capacity	60lt
Alimentazione	Power	220V (230V 50Hz)
Peso	Weight	145kg

Postazione di lavaggio unica, che lavora con due pompe separate, una per la bassa pressione che serve il pennello in plastica ed una ad alta pressione tarata a 90 bar per servire la pistola ad alta pressione. Dotata di illuminazione a led professionale, pianale in acciaio inox con 3 strati di filtraggio in discesa o in salita del liquido.

Single washing station, which works with two separate pumps, one for low pressure that serves the plastic brush and one at high pressure calibrated at 90 bar to serve the gun at high pressure. Equipped with professional LED lighting, steel platform stainless steel with 3 layers of downward or upward filtration of the liquid.

Detergente sgrassante per pulizia manuale di pezzi meccanici
Cleaning and degreasing product for the manual cleaning of mechanical parts

Codice / Code **MC-HP**

Contenuto
Product amount 10kg

KIT Ricambi
Spare parts kit

Codice / Code **MC-KR**



ARMADI - TOOL CABINETS



Armadi con larghezza da 50 e 100 cm da utilizzare come chiusura laterale di una composizione. Le porte sono dotate di chiusure self-closing (chiusura automatica) e gli scaffali interni sono completamente regolabili in altezza.

Tool cabinets with a width of 50 and 100 cm, to be used to harmonize a workshop set-up as end furnitures. The doors are equipped with self-closing latches and the internal shelves are fully adjustable in height.

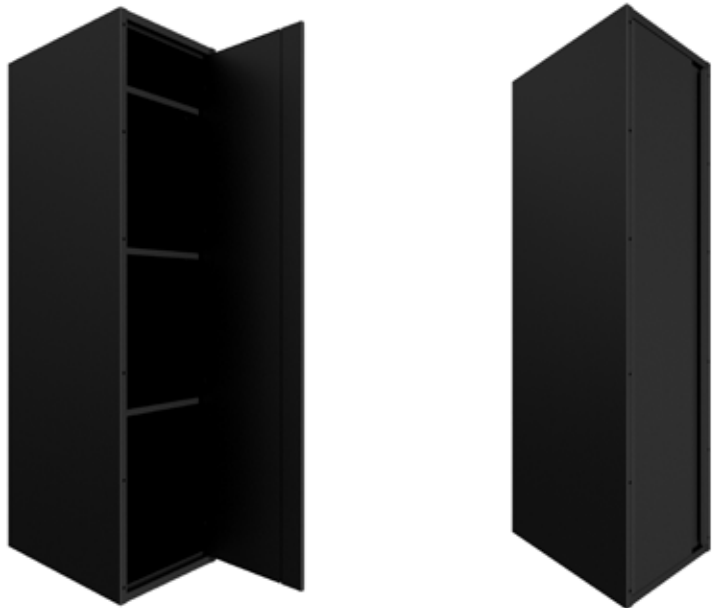

Codice / Code	MF-AR50
Dimensioni /Dimensions	2000x500x700 mm
Peso /Weight	90 kg



Codice / Code	MF-AR
Dimensioni /Dimensions	2000x1000x700 mm
Peso /Weight	180 kg



COPERTURE IN GOMMA E ACCIAIO INOX

Coperture in gomma antiolio

Oil resistant rubber covers

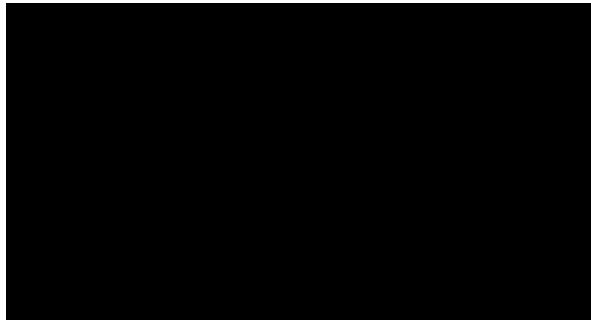

Codice / Code	Dimensioni/Dimensions
MF-PG2000-01/03	1995x795x3mm
MF-PG2000-01	1995x795x6mm
MF-PG1620-01/03	1615x795x3mm
MF-PG1620-01	1615x795x6mm
MF-PG1000-01/03	995x795x3mm
MF-PG1000-01	995x795x6mm

Codice / Code	Dimensioni/Dimensions
MF-PGANG-01/03	895x895x3mm
MF-PGANG-01	895x895x6mm

Punto attrezzato con presa schuko, presa LAN e slot vuoto. Sistema Pop-Up.

Pop-up with german socket, lan socket and free slot.



Codice / Code	Dimensioni/Dimensions
MF-BL/POP	120x142,5x5mm



Piano di lavoro e rinforzi completamente in acciaio inox disponibili per tutti i nostri banchi di lavoro.

Workable and reinforcing structures entirely made of stainless steel. Available for all our workbenches.



Codice / Code **MF-P-INOX**

Coperture sovrapponibili al piano di lavoro in acciaio inox disponibili per tutti i nostri banchi di lavoro.

Workable covers (to fit over the iron tabletop) made of stainless steel. Available for all our workbenches



Codice / Code **MF-C-INOX**

PANNELLI PORTA ATTREZZI E PENSILI



Griglia porta attrezzi
Wall tools grid



Codice / Code	Dimensioni/Dimensions
MF-PA2000-01	2000x810x190mm
MF-PA1620-01	1620x810x190mm
MF-PA1000-01	1000x810x190mm

Armadio porta attrezzi con serranda di chiusura e serratura.
Tool tray wall top chest with panel and lock.



Codice / Code	Dimensioni/Dimensions
MF-MA2000-01	2000x1000x200mm
MF-MA1620-01	1620x1000x200mm

Pensili
Cupboards



Codice / Code	Dimensioni/Dimensions
MF-BL M14	810x400x300mm
MF-BL M15	1000x400x300mm
MF-BL M20	1150x400x300mm



Pensile ad angolo
Corner cupboard

Codice / Code
MF-BL M17

Griglia di supporto per pensile ad angolo
Supporting wall grid for corner cupboard

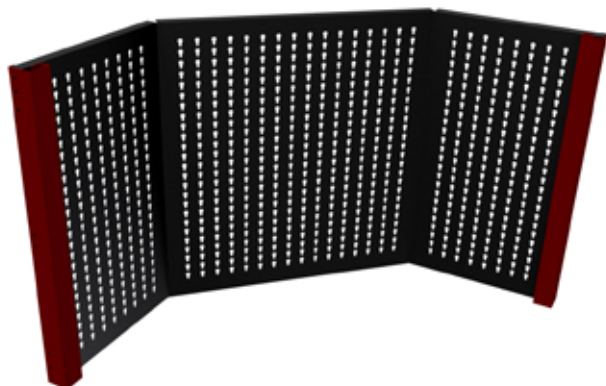

Codice / Code	MF-BL KGP/A
---------------	--------------------

Griglie per pensili
Grids for cupboards



Codice / Code	Dimensioni/Dimensions
MF-BL KGP2000	2000x625x55mm
MF-BL KGP1620	1620x625x55mm
MF-BL KGP1000	1000x625x55mm

Led per pensili
Cupboards Led



Codice / Code	Lunghezza/Lenght
MF-BL LED800	800mm
MF-BL LED1000	1000mm

GANCI - HOOKS

Codice / Code
MF-GPPLAST-01
Ø5mm L=35mm
Box 200pcs



Codice / Code
MF-GPPLAST-05
Ø5mm L=35mm
Occhiello /Eye hole Ø8mm
Box 100 pcs



Codice / Code
MF-VPTRASP-01
105x105x45 mm
Pezzo Singolo / One piece



Codice / Code
MF-GPPLAST-02
Ø5mm L=55mm
Box 100pcs



Codice / Code
MF-GPPLAST-06
Ø5mm L=38xmm
Occhiello /Eye hole Ø14mm
Box 100 pcs



Codice / Code
MF-VPTRASP-02
125x125x65 mm
Pezzo Singolo / One piece



Codice / Code
MF-GPPLAST-03
Ø5mm L=25mm
Box 100pcs



Codice / Code
MF-GPPLAST-07
Ø5mm L=50mm H=45mm
Box 100pcs



Codice / Code
MF-BPPUNTE-01
95x65x35 mm
Pezzo Singolo / One piece



Codice / Code
MF-GPPLAST-04
Ø5mm L=40mm
Box 100pcs



Codice / Code
MF-GPPLAST-08
Ø30mm L=75mm
Pezzo Singolo / One piece



			
Codice Code	MF-GPMETAL01/P	MF-GPMETAL02/P	MF-GPMETAL03/P
Dimensioni Dimensions	Ø5mm L=100mm	Ø5mm L=150mm	Ø5mm L=200mm
Box pcs.	100	50	50

HEXA

Kit luci a led per officine e showroom
Led lights kit ideal for workshops and showroom

NEW
2024

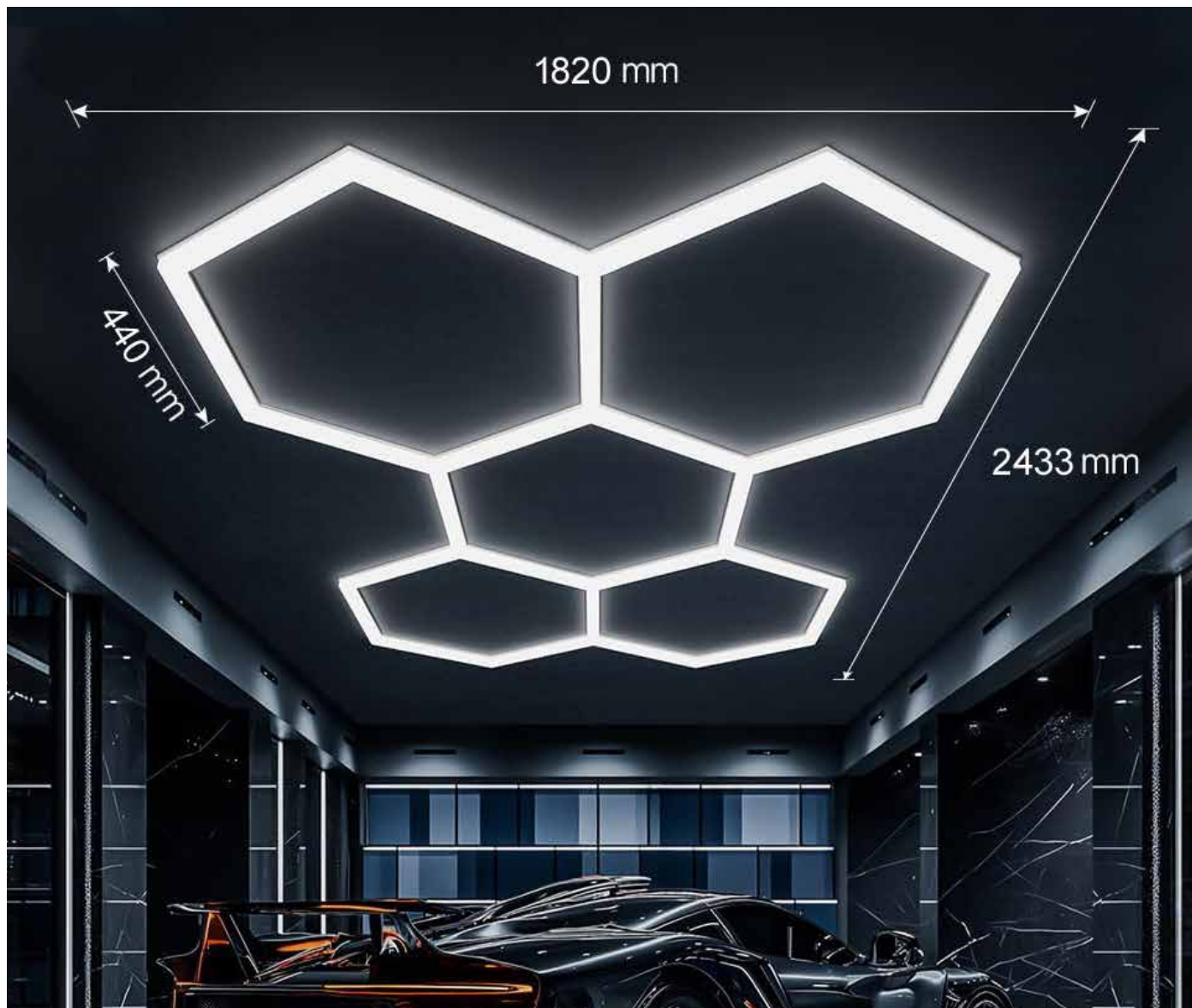

Parete divisoria attrezzata con pannello porta attrezzi a due facce e due ripiani. Montato su ruote girevoli.

*Double sided tool tray with shelves.
Mounted on pivoting castors*



Codice / Code	Dimensioni/Dimensions
MF-PD2000-01	2000x1940x350 mm

Scaffale per pneumatici appositamente studiato per lo stoccaggio delle gomme per moto e scooters.

Tyres shelf specifically designed for the storage of motorcycle and mopeds tyres.



Codice / Code	Dimensioni/Dimensions
MF-SP1500-01	1500x2350x350 mm

Carrello da officina con 3 ripiani

Workshop trolley with 3 shelves



Codice / Code	Dimensioni/Dimensions
MF-CO670-01	670x875x370 mm

Carrello da officina con 3 ripiani largo

Wide workshop trolley with 3 shelves



Codice / Code	Dimensioni/Dimensions
MF-CO900-01	900x1100x650 mm

SET DI ATTREZZI PER CASSETTIERE M1-M2-CB

Set 142 pezzi chiavi a cricchetto

142pcs flank socket set



Codice / Code

214201

Misure / Sizes

1/4" - 3/8"

Set 12 pezzi pinze

12pcs pliers set



Codice / Code

601207

Set 23 pezzi martelli, pinze, scalpelli e lime

23pcs hammers, pliers, chisel, files set



Codice / Code

602302

Set 27 pezzi cacciaviti

27pcs screwdrivers



Codice / Code

602716

Set 93 pezzi chiavi a cricchetto SAE

93pcs SAE flank sockets set



Codice / Code

309301 v.02

Misure / Sizes

1/4" - 3/8" - 1/2"

Set 21 pezzi cacciaviti bussola/viti esagonali

21pcs socket screw/hex grip key



Codice / Code

602104

SET DI ATTREZZI PER CASSETTIERE M1-M2-CB

Set 31 pezzi chiavi SAE
31pcs SAE wrenches set



Codice / Code

603101

Set 18 pezzi chiavi a brugola
18pcs hex ball grip key set

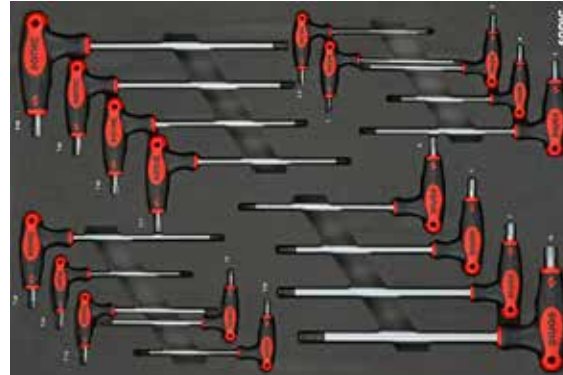

Codice / Code

601806

Misure/Sizes

2,2.5,3,4,5,6,7,8,10 mm

Set 50 pezzi combinati 1/2"
50pcs combination set 1/2"



Codice / Code

305002

Set 40 pezzi chiavi
40pcs wrenches set



Codice / Code

604002 v.2

Set 139 pezzi chiavi a cricchetto
139pcs bit socket set



Codice / Code

313902

Misure / Sizes

1/4" - 3/8" - 1/2"

Divisore in spugna
Foam spacer



Codice / Code

47612

M1-M2-CB DRAWERS MODULE SET OF TOOLS

Set 6 pezzi cacciaviti lunghi
6pcs long screwdriver set



Codice / Code	600625
---------------	---------------

Set 12 pezzi pinze
12pcs pliers set



Codice / Code	600825
---------------	---------------

Set 12 pezzi chiavi a cricchetto reversibile
12pcs reversible ratcheting wrench set



Codice / Code	601229
Misure/Sizes	8-19mm

Set 19 pezzi chiavi combinate SFS 1/3
19pcs combination wrench set SFS 1/3

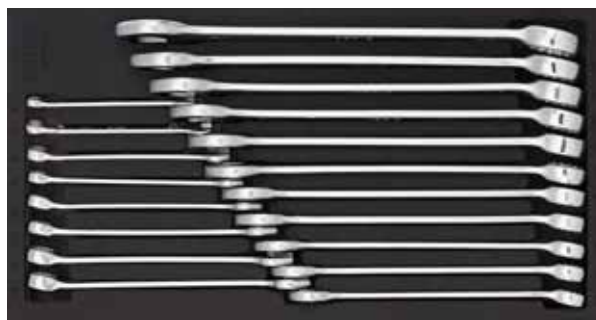

Codice / Code	601903
Misure/Sizes	6-24mm



RACING

MRA



MRF



Questi modelli possono essere composti da moduli e realizzati con colori a scelta del TEAM.

These models can be assembled and built with colors chosen by the TEAM

Alluminio Aluminium	
Codice / Code	MRA
Larghezza / Width	565 mm
Lunghezza / Length	1688 mm
Altezza / Height	900 mm
Peso / Weight	83 kg

Ferro Iron	
Codice / Code	MRF
Larghezza / Width	565 mm
Lunghezza / Length	1688 mm
Altezza / Height	900 mm
Peso / Weight	240 kg

Frutto della lunga collaborazione fra Bike-Lift Europe ed il Team GRESINI nasce l'MRA/MRF in alluminio o ferro, creato per ottimizzare gli interventi nel box e minimizzare i costi di trasporto nelle trasferte internazionali della MotoGP. Il modulo MRA ha un peso pari ad 1/3 di un modulo tradizionale, mantenendo le performances di robustezza e praticità necessarie ad un attrezzo a cui è richiesto ogni giorno di dimostrarsi professionale ed affidabile al 100%.

Created by the long cooperation between Bike-lift Europe and the GRESINI Team, the MRA/MRF in aluminium or iron version, has been developed to optimize the paddock operations and minimize the freight costs for the worldwide races of the MotoGP Championship. The MRA module weighs 1/3 of a traditional one but offers the same performances of strength and practical use required by a tool that has to prove every day to be 100% professional and reliable.

MRA-MXGP



MRS-MOTO 3



Alluminio Aluminium	
Codice / Code	MRA-MXGP
Larghezza / Width	565 mm
Lunghezza / Length	1868 mm
Altezza / Height	900 mm
Peso / Weight	93 kg

Versione del modulo MRA con sportello M3 anziché con il pannello servizi.

MRA racing module version featuring M3 module instead the service panel

L' MRS-MOTO3 è un altro dei numerosi prodotti sviluppati in collaborazione con il GRESINI Racing Team. Modulo dalle dimensioni più contenute rispetto ai precedenti, dal momento che deve posizionarsi ed essere operativo in spazi minori all'interno del paddock. Costruito in lamiera di ferro è molto compatto e modulabile sia in termini di colorazione che di servizi al suo interno.

The MRS-MOTO3 is another of the many products developed with the GRESINI Racing Team. It is a module featuring smaller sizes in comparison with the previous models, because it has to be positioned and be operative in smaller areas inside the paddock.

Built with iron plate it is very compact and can be modulable in terms of color and services inside it.

Ferro Iron	
Codice / Code	MRS-MOTO3
Larghezza / Width	565 mm
Lunghezza / Length	1258 mm
Altezza / Height	900 mm
Peso / Weight	138 kg

AL-BN



BL-TC/ALBN

OPTIONAL
Tappeto di protezione
OPTIONAL
Cover mat

Panca in alluminio pieghevole con rampa
Folding aluminium bench with ramp

Codice / Code	AL-BN
Larghezza / Width	600 mm
Lunghezza / Length	2000 mm
Altezza / Height	600 mm
Peso / Weight	25 kg

AL-DK



Completamente personalizzabile
Fully customizable

Scrivania da paddock in alluminio
Paddock desk in aluminium

Codice / Code	AL-DK
Larghezza / Width	700 mm
Lunghezza / Length	1500 mm
Altezza / Height	690 mm
Peso / Weight	25 kg

Scrivania da paddock interamente in alluminio.
Dotata di gambe pieghevoli per il trasporto.

Paddock desk fully made in aluminium.
Equipped with folding legs to avoid an easy transport.

AL-WT



Porta pneumatici da pitlane
Pitlane aluminium wheel trolley

Codice / Code	AL-WT
Larghezza / Width	550 mm
Lunghezza / Length	1400 mm
Altezza / Height	1480 mm
Peso / Weight	15 kg

MF-SR



Sedia racing da paddock
Racing chair for paddock

Codice / Code	MF-SR
Larghezza / Width	480 mm
Lunghezza / Length	670 mm
Altezza / Height	1100 mm
Peso / Weight	16 kg

Candelabri per pedane racing
Footpeg racing stand

Codice / Code	FPS-25 HIGH
Larghezza / Width	40 cm
Lunghezza / Length	20 cm
Altezza / Height	81 cm
Peso/Weight	5 kg



Cavalletto posteriore MOTO 3
Rear stand for MOTO 3

Codice / Code	RS-MOTO3
Larghezza / Width	40 cm
Lunghezza / Length	20 cm
Altezza / Height	81 cm
Peso/Weight	1,5 kg

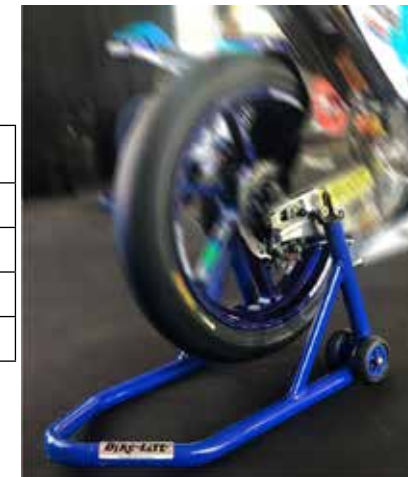

Cavalletto posteriore per telaio
KALEX moto 2 con adattatori a rullo
Rear stand for KALEX moto 2
frame with adapters

Codice / Code	RS-KALEX
Larghezza / Width	40 cm
Lunghezza / Length	20 cm
Altezza / Height	81 cm
Peso/Weight	2 kg

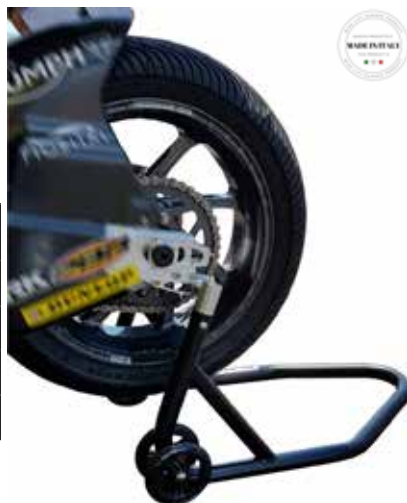

Supporto per trasporto e
stoccaggio motori con adattatori
universali

Support for the transport
and storage of engines,
with universal adapter pins
included.

Codice / Code	SM-19
Larghezza / Width	40 cm
Lunghezza / Length	20 cm
Altezza / Height	81 cm
Peso/Weight	5 kg



CAVALLETTI
STANDS

BLACK ICE

BI-RS



Black Ice cavalletto posteriore
Black Ice rear stand

Codice / Code	BI-RS
Larghezza / Width	52 cm
Lunghezza / Length	67 cm
Altezza / Height	37 cm
Peso / Weight	4 kg

BI-FS



Black Ice cavalletto anteriore
Black Ice front stand

Codice / Code	BI-FS
Larghezza / Width	41,5 cm
Lunghezza / Length	68 cm
Altezza / Height	34 cm
Peso / Weight	3,8 kg

Supporto in gomma *Rubber adapter*

Codice / Code	BI-SG
Larghezza Max / Max Width	33,5 cm
Larghezza Min / Min Width	27 cm



Supporto a forchetta *V-Shaped adapter*

Codice / Code	BI-SF
Larghezza Max / Max Width	36,5 cm
Larghezza Min / Min Width	29 cm



Patent design

Supporto a cono *Underfork adapter*

Codice / Code	BI-SC
Larghezza Max / Max Width	24 cm
Larghezza Min / Min Width	16 cm



Supporto a rullo pinze radiali *Radial calipers roller adapter*

Codice / Code	BI-SAP
Larghezza Max / Max Width	23,5 cm
Larghezza Min / Min Width	15,5 cm



Supporto in gomma piccolo *Small rubber adapter*

Codice / Code	BI-SGS
Larghezza Max / Max Width	23,5 cm
Larghezza Min / Min Width	15,5 cm



CAVALLETTI SMONTABILI



Cavalletto posteriore smontabile
in scatola
*Demountable rear stand with
box*

Codice / Code	RS-17/MK
Larghezza / Width	54 cm
Lunghezza / Length	67 cm
Altezza / Height	34 cm
Peso / Weight	3,9 kg

Cavalletto anteriore smontabile in
scatola
Demountable front stand in box

Codice / Code	FS-10/MK
Larghezza / Width	43 cm
Lunghezza / Length	67 cm
Altezza / Height	33 cm
Peso / Weight	3,7 kg



Su richiesta del cliente, per lotti minimi di produzione, è possibile realizzare altri colori RAL sia per tubolare che per le ruote.

On customers' demand, for moq of production, is possible to customize stands and wheels with RAL colors.



CAVALLETTI ANTERIORI

FS-10



Cavalletto anteriore regolabile
Adjustable front stand

Codice / Code	FS-10
Larghezza / Width	43 cm
Lunghezza / Length	67 cm
Altezza / Height	33 cm
Peso / Weight	3,7 kg

FS-9



Cavalletto anteriore fisso
Front stand

Codice / Code	FS-9
Larghezza / Width	35 cm
Lunghezza / Length	61 cm
Altezza / Height	32 cm
Peso / Weight	3 kg

Supporto in gomma
Rubber adapter

Codice / Code	SAG-10
Larghezza Max / Max Width	25 cm
Larghezza Min / Min Width	16 cm



Supporto a cono *Underfork adapter*

Codice / Code	SAC-10
Larghezza Max / Max Width	24,5 cm
Larghezza Min / Min Width	16 cm



Supporto a rullo *Roller adapter*

Codice / Code	SAR-10
Larghezza Max / Max Width	24 cm
Larghezza Min / Min Width	15 cm



Supporto a cono disassato *Misaligned underfork adapter*

Codice / Code	SAC-10/Y
Larghezza Max / Max Width	24,5 cm
Larghezza Min / Min Width	16 cm



Inserti rinforzati
Reinforced adapter head



Colori standard
Factory colors



Su richiesta del cliente, per lotti minimi di produzione, è possibile realizzare altri colori RAL sia per tubolare che per le ruote.

On customers' demand, for moq of production, is possible to customize stands and wheels with RAL colors.



Protezioni in gomma che hanno anche funzione di stabilizzare il cavalletto.

Protection pads that are also a mean to stabilize the stand

FRONT STANDS

FS-10/H



Cavalletto anteriore alto per pinze radiali con supporti SBG-10/P inclusi

High Front stand for radial calipers with SBG-10/P adapters includes

Codice / Code	FS-10/H
Larghezza / Width	43 cm
Lunghezza / Length	67 cm
Altezza / Height	35 cm
Peso / Weight	3,8 kg

FS-10/H-S



Cavalletto anteriore alto senza supporti inclusi

High front stand adapters not included

Codice / Code	FS-10/H-S
Larghezza / Width	43 cm
Lunghezza / Length	67 cm
Altezza / Height	33 cm
Peso / Weight	3,7 kg

Supporto in gomma piccolo
Small rubber adapters

Codice / Code	SBG-10/P
Larghezza Max / Max Width	24,5 cm
Larghezza Min / Min Width	16 cm



Inserti rinforzati
Reinforced adapter head

Supporto a rullo per pinze radiali
Radial calipers rubber adapter

Codice / Code	SAP-10
Larghezza Max / Max Width	23,5 cm
Larghezza Min / Min Width	15,5 cm



Protezioni in gomma che hanno anche funzione di stabilizzare il cavalletto.

Protection pads that are also a mean to stabilize the stand



Colori standard
Factory colors



Su richiesta del cliente, per lotti minimi di produzione, è possibile realizzare altri colori RAL sia per tubolare che per le ruote.

On customers' demand, for moq of production, is possible to customize stands and wheels with RAL colors.

CAVALLETTI SOTTOCANOTTO

FS-11



Cavalletto sottocanotto regolabile

Adjustable headstock stand

Codice / Code	FS-11
Larghezza / Width	48 cm
Lunghezza / Length	63 cm
Altezza max / Max height	82 cm
Altezza min / Min height	65 cm
Peso / Weight	7,1 kg



Protezioni in gomma che hanno anche funzione di stabilizzare il cavalletto.

Protection pads that are also a mean to stabilize the stand



Colori standard
Factory colors

Su richiesta del cliente, per lotti minimi di produzione, è possibile realizzare altri colori RAL sia per tubolare che per le ruote.



On customers' demand, for moq of production, is possible to customize stands and wheels with RAL colors.

Il cavalletto FS-11 è disponibile in due versioni: con un perno singolo a scelta del cliente oppure con il kit completo di 7 perni.

I codici sono:

Perno Singolo FS-11 901030101800
Kit 7 Perna FS-11 901030101100

The FS-11 stand is available in two versions: one including a single pin chosen by the customer or in alternative one with the complete kit of 7 pins.

The codes are:

Single pin FS-11 901030101800
Kit 7 pins FS-11 901030101100

Perni
Pins



ø27 ø23 ø20 ø18 ø17 ø15 ø13

OPTIONAL

Perno speciale per Ducati Panigale V4
Special pin for Ducati Panigale V4



ø28

FS-11/NEW



Cavalletto sottocanotto regolabile
Adjustable headstock stand

Codice / Code	FS-11/NEW
Larghezza / Width	37,5 cm
Lunghezza / Length	50 cm
Altezza max / Max Height	80 cm
Altezza min / Min Height	65 cm
Peso / Weight	11,7 kg



Perno universale conico

Universal cone pin



Piastra Ducati e MV Agusta

Ducati and MV Agusta plate



Colori standard
Factory colors



Su richiesta del cliente, per lotti minimi di produzione, è possibile realizzare altri colori RAL sia per tubolare che per le ruote.

On customers' demand, for moq of production, is possible to customize stands and wheels with RAL colors.

HEADSTOCK STANDS

FS-11/SPORT



Cavalletto sottocanotto
Headstock stand

Codice / Code	FS-11/SPORT
Larghezza / Width	37 cm
Lunghezza / Length	57 cm
Altezza max / Max Height	81,5 cm
Altezza min / Min Height	65,5 cm
Peso / Weight	7 kg



Perno universale conico

Universal cone pin



Perno pivotante in nylon per Ducati e MV Agusta

Pivoting nylon pin for Ducati and MV Agusta

CAVALLETTI POSTERIORI

RS-17



Cavalletto posteriore regolabile
Rear adjustable stand

Codice / Code	RS-17
Larghezza / Width	54 cm
Lunghezza / Length	67 cm
Altezza / Height	34 cm
Peso / Weight	3,9 kg



Colori standard
Factory colors



Su richiesta del cliente, per lotti minimi di produzione, è possibile realizzare altri colori RAL sia per tubolare che per le ruote.

On customers' demand, for moq of production, is possible to customize stands and wheels with RAL colors.

Supporto a forchetta
V-shaped adapter

Codice / Code	SAF-10
Larghezza Max / Max Width	37 cm
Larghezza Min / Min Width	30 cm



Supporti in gomma
Rubber adapter

Codice / Code	SBG-10
Larghezza Max / Max Width	34,5 cm
Larghezza Min / Min Width	27,5 cm



Protezioni in gomma che hanno anche funzione di stabilizzare il cavalletto.

Protection pads that are also a mean to stabilize the stand



Inserti rinforzati
Reinforced adapter head

REAR STANDS

RS-17/L



Cavalletto posteriore basso

Low rear stand

Codice / Code	RS-17/L
Larghezza / Width	54 cm
Lunghezza / Length	70 cm
Altezza / Height	31 cm
Peso / Weight	3,9 kg
Inclusi / Included	SAF-10

RS-17/XL



Cavalletto posteriore extra basso

Extra low rear stand

Codice / Code	RS-17/XL
Larghezza / Width	58 cm
Lunghezza / Length	70,5 cm
Altezza / Height	28,5 cm
Peso / Weight	3,9 kg
Inclusi / Included	SAF-10



Colori standard
Factory colors

Su richiesta del cliente, per lotti minimi di produzione, è possibile realizzare altri colori RAL sia per tubolare che per le ruote.

On customers' demand, for moq of production, is possible to customize stands and wheels with RAL colors.



Inserti rinforzati

Reinforced adapter head



Protezioni in gomma che hanno anche funzione di stabilizzare il cavalletto.

Protection pads that are also a mean to stabilize the stand



Confezione con viti incluse
Packaging with screws includes



Espositore 24 confezioni
24 boxes displayer

Nottolini in alluminio
Aluminium bobbins



M10 Passo disponibile / Available Thread 1,25 - 1,50 mm

Codice / Code	M6	M8	M10
Rosso / Red	NA-M6/R	NA-M8/R	NA-M10/R
Blu / Blue	NA-M6/B	NA-M8/B	NA-M10/B
Nero / Black	NA-M6/N	NA-M8/N	NA-M10/N
Titanio / Titanium	NA-M6/T	NA-M8/T	NA-M10/T

CAVALLETTI MONOBRACCIO

RS-16



Cavalletto posteriore monobraccio
Single swing arm rear stand

Codice / Code	RS-16
Larghezza / Width	55 cm
Lunghezza / Length	70 cm
Altezza / Height	42,5 cm
Peso / Weight	5,6 kg



Protezioni in gomma che hanno anche funzione di stabilizzare il cavalletto.

Protection pads that are also a mean to stabilize the stand



Colori standard

Factory colors



Codice / Code	PMB-1200K
Modello / Model	BMW
∅	53 mm



Codice / Code	PMH-CB08-18
Modello / Model	HONDA CB 2018-2020
∅	18,1 mm



Codice / Code	PMD-01
Modello / Model	DUCATI
∅	21,8/25,9 mm



Codice / Code	PMH-01
Modello / Model	HONDA
∅	28,7 mm



Codice / Code	PMM-01
Modello / Model	MV AGUSTA
∅	42,5 mm



Codice / Code	PMD-98/40
Modello / Model	DUCATI
∅	40,5 mm



Codice / Code	PMG-V100
Modello / Model	GUZZI v100
∅	52,5 mm



Codice / Code	PMT-01
Modello / Model	TRIUMPH - KTM S.DUKE
∅	27,5 mm



Codice / Code	PMH-CB08
Modello / Model	HONDA CB 1000 R 2008-2017 & 2021-2024
∅	28,25 mm

REAR SINGLE SWING ARM STANDS

RS-16/R



Cavalletto posteriore
monobraccio destro
Rear right single swing arm
stand

Codice / Code	RS-16/R
Larghezza / Width	55 cm
Lunghezza / Length	70 cm
Altezza / Height	42,5 cm
Peso / Weight	5,6 kg



Su richiesta del cliente, per lotti minimi di produzione, è possibile realizzare altri colori RAL sia per tubolare che per le ruote.

On customers' demand, for moq of production, is possible to customize stands and wheels with RAL colors.



Codice / Code	PMD-01/R
Modello / Model	DUCATI
∅	29,8 mm



Codice / Code	PMB-650
Modello / Model	BMW F650CS-F800-S/ST
∅	30 mm



Codice / Code	PMB-1200
Modello / Model	BMW R1200 GS
∅	51 mm



Codice / Code	PMB-1200K
Modello / Model	BMW
∅	53 mm



Protezioni in gomma che hanno anche funzione di stabilizzare il cavalletto.

Protection pads that are also a mean to stabilize the stand

CAVALLETTI POSTERIORI

RS-18/F



Cavalletto posteriore fisso con supporti a forchetta
Fixed rear stand with V-adapters

Codice / Code	RS-18/F
Larghezza / Width	41 cm
Lunghezza / Length	63 cm
Altezza / Height	37,5 cm
Peso / Weight	3,9 kg
Supporti a forchetta V-shaped adapters	Inclusi Included

RS-18/G



Cavalletto posteriore fisso con supporti in gomma
Fixed rear stand with rubber adapters

Codice / Code	RS-18/G
Larghezza / Width	41 cm
Lunghezza / Length	60 cm
Altezza / Height	31 cm
Peso / Weight	3,9 kg
Supporti in gomma Rubber adapters	Inclusi Included



Su richiesta del cliente, per lotti minimi di produzione, è possibile realizzare altri colori RAL sia per tubolare che per le ruote.

On customers' demand, for moq of production, is possible to customize stands and wheels with RAL colors.



Protezioni in gomma che hanno anche funzione di stabilizzare il cavalletto.

Protection pads that are also a mean to stabilize the stand

REAR STANDS

RS-17/TB



Cavalletto posteriore Triumph Bonneville
Triumph Bonneville rear stand

Codice / Code	RS-17/TB
Larghezza / Width	43 cm
Lunghezza / Length	62 cm
Altezza / Height	36,5 cm
Peso / Weight	2,8 kg



Su richiesta del cliente, per lotti minimi di produzione, è possibile realizzare altri colori RAL sia per tubolare che per le ruote.

On customers' demand, for moq of production, is possible to customize stands and wheels with RAL colors.



RS-17/SCRAMBLER



Cavalletto posteriore Ducati Scrambler
Ducati Scrambler rear stand

Codice / Code	RS-17/SCRAMBLER
Larghezza / Width	55 cm
Lunghezza / Length	67 cm
Altezza / Height	30 cm
Peso / Weight	3,8 kg
Supporti Adapters	Inclusi Included



Protezioni in gomma che hanno anche funzione di stabilizzare il cavalletto.

Protection pads that are also a mean to stabilize the stand

CAVALLETTI POSTERIORI

RS-Q



Cavalletto per Quad

Quad rear stand

Codice / Code	RS-Q
Larghezza / Width	41 cm
Lunghezza / Length	63 cm
Altezza / Height	37,5 cm
Peso / Weight	6,9 kg



Colori standard
Factory colors



Su richiesta del cliente, per lotti minimi di produzione, è possibile realizzare altri colori RAL sia per tubolare che per le ruote.

On customers' demand, for moq of production, is possible to customize stands and wheels with RAL colors.

RE-M



Cavalletto posteriore Easy Mover
Easy Mover rear stand

Codice / Code	RE-M
Larghezza / Width	64 cm
Lunghezza / Length	73 cm
Altezza / Height	32,5 cm
Peso / Weight	8,2 kg
Utilizzabile solo Available only with	SAF-10



Protezioni in gomma che hanno anche funzione di stabilizzare il cavalletto.

Protection pads that are also a mean to stabilize the stand

REAR STANDS

RS-S



Cavalletto posteriore per Scooter
Moped rear stand

Codice / Code	RS-S
Larghezza / Width	54 cm
Lunghezza / Length	57 cm
Altezza / Height	33 cm
Peso / Weight	3,5 kg
Supporti Adapters	non inclusi not included



Colori standard
Factory colors



Su richiesta del cliente, per lotti minimi di produzione, è possibile realizzare altri colori RAL sia per tubolare che per le ruote.

On customers' demand, for moq of production, is possible to customize stands and wheels with RAL colors.



Protezioni in gomma che hanno anche funzione di stabilizzare il cavalletto.

Protection pads that are also a mean to stabilize the stand



Codice / Code

RS-S-MI

Adattatore
Minarelli
Minarelli adapter



Codice / Code

RS-S-PEU

Adattatore
Peugeot
Peugeot adapter



Codice / Code

RS-S-PIA

Adattatore
Piaggio
Piaggio adapter

CENTER STAND

CS-24N



Cavalletto centrale
Central stand

Codice / Code	CS-24N
Larghezza / Width	56 cm
Lunghezza / Length	48 cm
Altezza / Height	57 cm
Peso / Weight	5,2 kg



Codice / Code	CS-UP
Modello / Model	Universale / Universal

Perni non inclusi
Pins not included



Codice / Code	CS-VFR
Modello / Model	HONDA VFR 1200

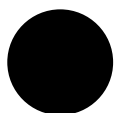

Colore standard
Factory color



Su richiesta del cliente, per lotti minimi di produzione, è possibile realizzare altri colori RAL sia per tubolare che per le ruote.

On customers' demand, for moq of production, is possible to customize stands and wheels with RAL colors.

PADDOCK STANDS

WP-400



Piattaforma di parcheggio
Wheel parking platform

Codice / Code	WP-400
Larghezza / Width	46,8 cm
Lunghezza / Length	51 cm
Altezza / Height	5,9 cm
Peso / Weight	8 kg
Portata / Max load	400 kg

SE-400



Estensione per cavalletto laterale
Extension for side stand

Codice / Code	SE-400
Larghezza / Width	14 cm
Lunghezza / Length	86,5 cm
Altezza / Height	6,5 cm
Peso / Weight	6 kg
Portata / Max load	400 kg

FPS-25



Cavalletti regolabili per pedane
racing
Footpegs' adjustable rear stand

Codice / Code	FPS-25
Larghezza / Width	40 cm
Lunghezza / Length	20 cm
Altezza max/Height max	43 cm
Altezza min/Height min	37 cm
Peso / Weight	3,7 kg

ERGAL STANDS

RS-17/E



Cavalletto posteriore in ergal
Ergal adjustable rear stand

Codice / Code	RS-17/E
Larghezza / Width	54 cm
Lunghezza / Length	67 cm
Altezza / Height	34 cm
Peso / Weight	2 kg



Supporti a forchetta - inclusi
V-shaped adapters - included

Larghezza Max / Max Width	37 cm
Larghezza Min / Min Width	30 cm



Inserti rinforzati
Reinforced adapter head



Protezioni in gomma che hanno anche funzione di stabilizzare il cavalletto.
Protection pads that are also a mean to stabilize the stand

FS-10/E



Cavalletto anteriore in ergal
Ergal adjustable front stand

Codice / Code	FS-10/E
Larghezza / Width	43 cm
Lunghezza / Length	67 cm
Altezza / Height	33 cm
Peso / Weight	2 kg



Supporti a cono - inclusi
Underfork adapters - included

Larghezza Max / Max Width	24,5 cm
Larghezza Min / Min Width	16 cm



OFFROAD STANDS

PP/E



PP/E-R



KS-2012



SKS-2012



Cavalletto cross

Offroad stand

Codice / Code	PP/E
Larghezza / Width	24 cm
Lunghezza / Length	24 cm
Altezza / Height	43 cm
Portata / Max load	150 kg

PP/E-R rosso / red

Cavalletto per offroad

Offroad stand

Codice / Code	KS-2012
Larghezza / Width	21 cm
Lunghezza / Length	28 cm
Altezza max / Height max	43,3 cm
Altezza max / Height max	31,5 cm
Portata / Max load	160 kg

Cavalletto per Motard

Motard stand

Codice / Code	SKS-2012
Larghezza / Width	21 cm
Lunghezza / Length	28 cm
Altezza max / Height max	37,5 cm
Altezza max / Height max	25,7 cm
Portata / Max load	160 kg

FLUO & COLORED COLLECTION



ATTREZZATURE PROFESSIONALI
PROFESSIONAL EQUIPMENT

BIKE-21N



Smontagomme semiautomatico per motocicli, scooters, quad, go-karts e macchine da giardinaggio. E' ideale per utilizzatori che necessitano di un sistema di stallonatura tradizionale.

Il piatto auto-centrante permette di serrare cerchi da 6" a 24".

Le principali caratteristiche sono :

- Braccio orizzontale a ribaltamento laterale e bloccaggio manuale del braccio verticale porta utensile.
- Piatto auto-centrante avente capacità da 6" a 24" grazie a 3 differenti posizioni di bloccaggio facilmente selezionabili senza necessità di utensili.
- Sistema di stallonatura tradizionale dotato di specifica paletta con protezione.
- Torretta di montaggio con inserti in plastica per cerchi in lega

Semi-automatic tyres charger designed to mount and demount motorcycle, mopeds, ATV, Quads, Go-karts and turf vehicles. It is conceived for operators looking for a traditional bead breaking system.

The self-centering turntable locks rims from 6" to 24" with the standard adapters supplied.

The main features are:

- Proven and reliable semi-automatic swing arm configuration and manual locking system of the vertical working arm.
- Self-centering turntable with capacity from 6" to 24" performing 3 different clamping positions easily selectable without the use of extra tools.
- Traditional bead braking system equipped with a specific rim protection cover.
- Tool head supplied with plastic protection inserts for alloy rims.

Codice / Code	BIKE-21N/230V	BIKE-21N/380V
Potenza / Power	230V	380V
Aria / Air	08-10 bar	08-10 bar
Potenza motore / Engine power	0.75/1 Kw	0.75/1 Kw
Apertura griffe / Clamp range	6"-24"	6"-24"
Forza stallonatore / Bead breaker power	2500 kg	2500 kg
Apertura max stallonatore / Bead breaker max opening	310 mm	310 mm
Diametro max ruota / Wheel max diameter	960 mm	960 mm
Larghezza max ruota / Wheel max width	250 mm	250 mm
Velocità rotazione / Rotation speed	6 Rpm	6 Rpm
Peso / Weight	174 kg	174 kg
Dimensioni / Dimensions	1830x1060x1020 mm	1830x1060x1020 mm

Dotazione di serie	Standard Equipment
Torretta in ferro	Iron head
Torretta in teflon con attacco	Teflon head for motorcycle with fitting
Protezione stallonatore	Bead breaker protection
Griffe standard	Standard rim clamps
Griffe CKM	CKM rim clamps

BIKE-35N



Smontagomme automatico professionale per motocicli, scooters, quad, go-karts e macchine da giardinaggio.

E' ideale per utilizzatori che necessitano di un sistema di stallonatura tradizionale. Il piatto auto-centrante permette di serrare cerchi da 6" a 26".

Le principali caratteristiche sono:

- Palo verticale dotato di sistema recupero giochi a boccole coniche.
- Piatto auto-centrante a doppio senso di rotazione dotato di bielle curve per mantenere costante la forza di serraggio al variare del diametro del cerchio.
- Sistema di stallonatura tradizionale dotato di specifica paletta con protezione.
- Torretta di montaggio con inserti in plastica per cerchi in lega

Automatic professional tyre changer, designed to mount and demount motorcycle, mopeds, ATV, Quads, Go-karts and turf vehicles. It is conceived for operators looking for a traditional bead breaking system.

The self-centering turntable locks rims from 6" to 26" with the standard adapters supplied.

The main features are:

- Vertical post equipped with conic bushes to recover clearances which could appear after an intensive use of the machine.
- 2 ways rotation turntable clamping system which employs unique rod geometry to constant and even clamping power throughout all rim diameters.
- Traditional bead braking system equipped with a specific rim protection cover.
- Tool head supplied with plastic protection inserts for alloy rims.

Codice / Code	BIKE-35N/230V	BIKE-35N/380V
Potenza / Power	230V	380V
Aria / Air	08-10 bar	08-10 bar
Potenza motore / Engine power	0.75/1 Kw	0.75/1 Kw
Apertura griffe / Clamp range	6"-26"	6"-26"
Forza stallonatore / Bead breaker power	3000 kg	3000 kg
Apertura max stallonatore / Bead breaker max opening	330 mm	330 mm
Diametro max ruota / Wheel max diameter	1000 mm	1000 mm
Larghezza max ruota / Wheel max width	250 mm	250 mm
Velocità rotazione / Rotation speed	6 Rpm	6 Rpm
Peso / Weight	250 kg	250 kg
Dimensioni / Dimensions	1720x1100x930 mm	1720x1100x930 mm

Dotazione di serie	Standard Equipment
Torretta in ferro	Iron head
Torretta in teflon con attacco	Teflon head for motorcycle with fitting
Protezione stallonatore	Bead breaker protection
Griffe standard	Standard rim clamps
Griffe CKM	CKM rim clamps

BIKE-SM



Nuovo modello disponibile
da Febbraio 2026
*New model available
since February 2026*

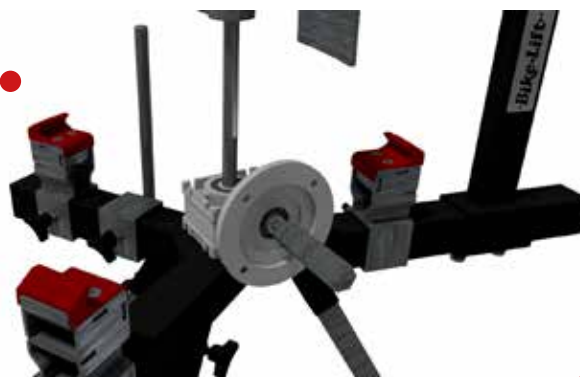

INCLUSI / INCLUDED

ISTRUZIONI D'USO



HOW TO USE

Smontagomme manuale portatile

Manual portable tyre charger

Codice / Code	BIKE-SM
Diametro ruota / Wheel diameter	12"-21"
Peso / Weight	20 kg

Dotazione di serie Standard Equipment

Leva	Lever
Premi tallone	Bead Breaker
1 kg Sapone	Lubricant 1 kg

Smonta gomme manuale, completamente smontabile e quindi facilmente trasportabile sul tracciato di gara. Di facile utilizzo è in grado di stallonare qualsiasi tipo di pneumatico moto con diametri ruota da 12" a 21". Viene fornito con leva in acciaio, premi tallone e lubrificante da 1kg

Manual tyre changer, fully foldable for an easy carrying onto the race tracks. It is easy to use and it is able to break any type of motorcycle tyre with diameters from 12" up to 21". It is supplied with steel lever, bead breaker push and a 1kg jar of tyre lube.

ACCESSORIES

Flangia per utensile BL-221618
BL-221618 demount head flange

Codice / Code

DHF



Torretta in acciaio per scooter 8"
8" moped stainless steel
demount head

Codice / Code

TRS



Set 5 inserti in plastica per torretta 2K
2K demount head 5pcs kit
plastic inserts

Codice / Code

IP2-2K



Corpo utensile in plastica
Plastic demount head

Codice / Code

CUP



Utensile in plastica
Plastic demount head

Codice / Code

BL-221618



Kit 4 pezzi griffe bloccaggio
4pcs kit rim clamps

Codice / Code

CKM



Utensile in plastica con attacco rapido
Plastic demount head with
fast-lock fitting

Codice / Code

UPA



Torretta in teflon
Demount head

Codice / Code

20015111



Kit 4 protezioni in plastica per griffe
4pcs kit rim clamps plastic protections

Codice / Code

GKS



Torretta in acciaio 13"-23"
13"-23" stainless steel demount head

Codice / Code

MC-98



Set 5 inserti in plastica per torretta 2K
2K demount head 5pcs kit
plastic inserts

Codice / Code

IP1-2K



Kit 4 griffe ruote da cross 5"-25"
4pcs kit off-road clamps 5"-25"

Codice / Code

UCA



ACCESSORI

Kit 4 griffe bloccaggio ruote ATV
4pcs kit ATV tyres locking clamps

Codice / Code

ATV



Kit 6 protezioni in
plastica stallonatrice
6pcs bead breaker
plastic protection kit

Codice / Code

PPM



Kit 4pz adattatori bloccaggio ruote kart
4pcs kit kart wheels locking
adapters kit

Codice / Code

KIT GK



Lubrificante 1kg
1kg lubricant
grease

Codice / Code

BL-TL



Protezione cerchioni
Rim protectors

Codice / Code

KA-7023



Rimuovi piombi in plastica
Rim weight remover

Codice / Code

WR-27



Leva con protezione
Lever with protection

Codice / Code

BL-4330

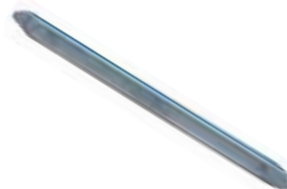

Set 3 leve in acciaio professionali
3pcs professional kit iron tyre levers

Codice / Code

BL-4540



Smonta valvole pneumatici
Stubby valve core remover

Codice / Code

BL-4980



Pinza rimuovi
piombi

Wheel weight
balance pliers

Codice / Code

BL-4474001



Confezione da 50 strisce da 45gr cadauna
Package of 50 stripes 45gr each



Codice / Code	Colore / Color
BL-PSC-A	Arancio/Orange
BL-PSC-B	Blu/Blue
BL-PSC-G	Grigio/Grey
BL-PSC-N	Nero/Black
BL-PSC-O	Oro/Gold
BL-PSC-R	Rosso/Red
BL-PSC-V	Verde/Green
BL-PSC-W	Bianco/White

Pistola ad impulsi

Power impact gun

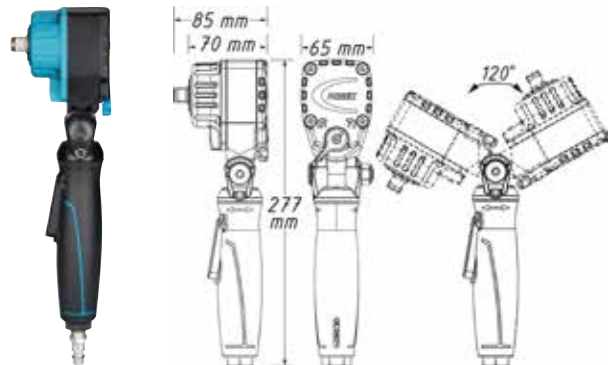

Codice / Code	BL-11261790
Coppia di serraggio Tightening torque	500 Nm
Coppia raccomandata Recommended torque	450 Nm
Impulsi/Pulses	8000/min
Ingresso aria/Air inlet	1/4"
Vibrazioni a vuoto Idle vibrations	4,9 m/s ²
Rumorosità a vuoto/Idle noise	90,1 dB(A)
Peso/Weight	1,3 kg

Set 5 chiavi 1/2" per pistola ad impulsi
5pcs power impact socket set 1/2"



Codice / Code	Misure / Sizes
BL-300507	15-17-19-21-22 mm

Manometro di gonfiaggio
pneumatici analogica

Analogic tyre pressure
gauge manometer

Codice / Code

BL-11399400



Manometro di gonfiaggio
pneumatici digitale

Digital tyre pressure
gauge manometer

Codice / Code

BL-11399800



ACCESSORIES

Pistola di soffiaggio regolabile

Air blow gun adjustable



Codice / Code

BL-KPA430

Pistola di soffiaggio

Air blow gun



Codice / Code

BL-KPA030/12

BIKE-62N



Equilibratrice elettronica con programmi distinti per moto e quad.

Presenta la caratteristica esclusiva di poter tarare unicamente la flangia moto senza il relativo gruppo meccanico, quindi con risultati più precisi. Sulla base sono predisposti dei supporti per ruote per poter rendere trasportabile la macchina, rendendola ideale per il servizio mobile. Per agevolare questi tipo di servizio la macchina può essere alimentata anche a 12-24V tramite l'apposito alimentatore fornito con presa per accendisigari auto. La macchina viene fornita con un corredo accessori completo per la messa in opera immediata e senza necessità di ulteriori accessori.

Le caratteristiche principali sono :

- Lancio manuale della ruota.
- Acquisizione manuale dei dati geometrici della ruota.
- Freno di stazionamento a pedale.
- Calibrazione gruppo flangia senza il relativo gruppo meccanico.
- 2 programmi di bilanciatura ruote (statico e dinamico).
- Programma divisione pesi.
- Programma pesi nascost

Electronic wheel balancer featuring two separate balancing

programs for motorcycles and quads. It has the unique feature of calibrating the single motorbike group, thus assuring a more accurate results.

The base is provided of dedicated feet to which connect casters and so making the machine movable and ideal for a mobile service. To allow this service the machine can work with 12-24V with the use of a specific cable supply included in the accessories that can be plug into the car lighter socket.

The machine is supplied with a comprehensive set of accessories for its immediate operativity, without the need of extra tools.

The main features are:

- *Hand spin of the wheel.*
- *Manual acquisition of the geometric wheel data.*
- *Mechanical pedal brake.*
- *Flange calibration without the motorbike mechanical group.*
- *2 balancing programs (static and dynamic).*
- *Split weight program.*
- *Hidden weight program*

Codice / Code	BIKE-62N
Potenza / Power	230V
Peso max ruota / Max wheel weight	70 kg
Diametro max ruota / Wheel max diameter	1120 mm
Larghezza cerchio / Rim width	590 mm
Diametro cerchio impostabile / Settable rim diameter	8"-35"
Precisione squilibrio / Balancing precision	1 gr
Velocità di equilibratura / Balancing speed	5,5 sec
Velocità rotazione / Rotation speed	<100 Rpm
Peso / Weight	80 kg
Dimensioni / Dimensions	1250x420x1050 mm

Dotazione di serie

Standard Equipment



BENCH MOTO MEC



Equilibratrice elettronica da banco

Electronic workbench
wheel balancer

Le dimensioni estremamente ridotte la rendono la soluzione ideale per chi ha esigenze di spazio ma non solo.

È infatti la giusta scelta per l'uso in pista o per il servizio mobile, dove sia necessario spostare ed utilizzare l'equilibratrice in posti diversi.

The BENCH MOTO MEC is the ideal solution for working areas with reduced space, but not only. It is also the best choice for racetracks or for a mobile service, wherever may be necessary to use the wheel balancer in different places.



Codice / Code	BIKE-MOTO-MEC
Potenza / Power	220V / 12V
Peso max ruota / Max wheel weight	50 kg
Diametro max ruota / Wheel max diameter	890 mm
Larghezza cerchio / Rim width	500 mm
Diametro cerchio impostabile / Settable rim diameter	8"-35"
Precisione squilibrio / Balancing precision	1 gr
Velocità di equilibratura / Balancing speed	5,5 sec
Velocità rotazione / Rotation speed	80 Rpm
Peso / Weight	40 kg
Dimensioni / Dimensions	360x360 mm

Dotazione di serie

Standard Equipment



ACCESSORI



Codice / Code	A-141
Modello / Model	BMW
Ø Perno / Pin	14 mm



Codice / Code	A-191
Modello / Model	Harley Davidson
Ø Perno / Pin	19 mm



Codice / Code	A-192
Modello / Model	Suzuki
Ø Perno / Pin	19 mm



Codice / Code	A-199
Modello / Model	Ducati/Triumph
Ø Perno / Pin	19 mm



Codice / Code	A-193
Modello / Model	Aprilia - Bmw - Yamaha
Ø Perno / Pin	19 mm



Codice / Code	A-194
Modello / Model	Harley Davidson V-Road
Ø Perno / Pin	19 mm



Codice / Code	A-195
Modello / Model	Centraggio 25mm Centering 25mm
Ø Perno / Pin	19 mm

Bloccaggio rapido perno
Quick lock for pin



Codice / Code	Ø Perno / Pin
BR-14	14 mm
BR-19	19 mm



Codice / Code	A-196
Modello / Model	Centraggio 35mm Centering 35mm
Ø Perno / Pin	19 mm



Codice / Code	A-197
Modello / Model	Honda 650-GL1800
Ø Perno / Pin	19 mm



Codice / Code	A-198
Modello / Model	MV Agusta
Ø Perno / Pin	19 mm



Codice / Code	Ø Perno / Pin
PB14-B62	14 mm
PB19-B62	19 mm

BL-124-00

Bilanciatrice Statica

Bilanciatrice statica completa di tutti gli accessori necessari al bilanciamento e centraggio dei cerchi della maggioranza dei modelli moto e scooters. E' fornita di asta in acciaio di 12mm di diametro con coni per ruote da 10" a 21", ruotante su cuscinetti a sfera in acciaio. Perni regolabili a punta conica da 16mm a 30mm ed asta per il centraggio dei cerchi a raggi con check-point a 90°. Fornita anche di livella a bolla incorporata. Fornita in scatola di montaggio

Static wheel balancer

Static balancer supplied with all necessary tools for the balancing and centering of the rims of almost all models of motor-cycles and mopeds. It is supplied with a steel shaft bar of 12mm diameter with cones for wheels from 10" up to 21", spinning on stainless steel ball bearings, tapered cone axle stoppers from 16 up to 30mm and rim centering bar at 90°. It is equipped with a level-eye. Supplied in assembling kit box.



Bilanciatrice statica
Static Wheel Balancer

Codice / Code	BL-124-00
Diametro ruota / Wheel diameter	12"-21"
Peso / Weight	10 kg

B-35N



Monta valvole pneumatici Revolving nozzle



Codice / Code

BS-R

Bilanciatrice statica Static Wheel Balancer

Codice / Code	B-35N
Diametro ruota / Wheel diameter	12"-21"
Peso / Weight	10 kg

Bilanciatrice Statica

Bilanciatrice statica utilizzabile su tutte le ruote fino a 21".
Progettata per ottimizzare la logistica delle spedizioni, per facilitare il montaggio e per migliorare l'estetica ed il design, nonché completarne la funzionalità con nuovi accessori.
Veloce da montare, meno ingombrante e più leggera, la B-35N offre tutte le funzionalità necessarie nell'ambito della bilanciatura.
Fornita con asta in acciaio da 12mm e coppia di coni con diametro massimo da 40mm.
Fornita in scatola di montaggio.

Static wheel balancer

Static balancer applicable on all kind of wheels till 21". Designed to obtain a better logistic size to have an easier assembling procedure, to achieve a better design and complete the functionality with new accessories.
Quick to assemble, reduced dimensions and lighter in weight, it offers all the necessary functionalities when working on wheel balancing.
Supplied with a 12mm stainless steel shaft bar and a pair of cones with maximum diameter of 40mm. Supplied in assembling kit box

ACCESSORI

Kit 3 coni componibili e due dadi di fermo che permette di lavorare su tutti i cerchi moto e scooter

3pcs cones and 2pcs nuts kit for operating on all the motorcycles and mopeds rims



Codice / Code	B-AU
---------------	-------------



Codice / Code	B-A00
Modello / Model	Standard
Ø Perno / Pin	12 mm



Codice / Code	B-A01
Modello / Model	Monobraccio DUCATI HONDA TRIUMPH



Codice / Code	B-A02
Modello / Model	BMW <2006 R65, R80, R100



Codice / Code	B-A03
Modello / Model	Maxi Scooter
Ø Perno / Pin	10 mm



Codice / Code	B-A04
Modello / Model	Piaggio X9



Codice / Code	B-A05
Modello / Model	BMW > 2006 K1200, R1200



Codice / Code	BL-124-01
Modello / Model	BMW 1200 R1200 GS

ENGINE STAND



Supporto motore con ruote
Engine stand with casters

Codice / Code	ES-06
Portata massima / Max load	200 kg
Dimensioni / Dimensions	500x700x1200 mm
Peso / Weight	25 kg

Flangia per motori Ducati
Ducati engine's flange

Codice / Code

ES-06/DUC



Flangia per motori maxi scooter
Maxi scooters' engine flange

Codice / Code

ES-06/AS



SA-07



Smonta ammortizzatori
Shock absorber disassembler

Codice / Code	SA-07
Dimensioni / Dimensions	250x250x1000 mm
Peso / Weight	20 kg

Dotazione Standard
Standard Equipment



Diametro Diameter	mm
∅	45
∅	47
∅	50
∅	53
∅	56
∅	59
∅	62
∅	66
∅	68
∅	71
∅	75
∅	77
∅	80
∅	83
∅	87

BL-4822331



Capretta
Foldable Engine Crane

Codice / Code	BI-4822331
Capacità / Capacity	1000kg
Altezza min / Min height	334mm
Altezza min / Min height	2120mm

PRESSE

PS-30



PS-15



Pressa 30ton
30ton hydraulic press

Codice / Code	PS-30
Altezza/height	1850mm
Lunghezza/Legth	840mm
Larghezza/width	540mm
Peso / Weight	132 kg

Pressa 15ton
15ton hydraulic press

Codice / Code	5953
Altezza/height	1015mm
Lunghezza/Legth	678mm
Larghezza/width	480mm
Peso / Weight	54 kg

ATTREZZATURE - EQUIPMENT



Cavo aria con tubo in PU	Air hose with PU tube
Codice / Code	AM80/8
Lunghezza cavo Hose length	10 mt
Codice / Code	AM85/8
Lunghezza cavo Hose length	15 mt

Cavo elettrico con protezione anti-riscaldamento	Electric cable with over-heat protection
Codice / Code	AM40/315
∅	2mm
Cavo /Hose	3Gx1,5mm
Lunghezza cavo Hose length	15 mt + 1 mt



NEW
2024

Vasca portafusti	Sump pallets
Codice / Code	VPF-01
Fusto Drum	1 pc
Capacità Capacity	120 lt.

Vasca portafusti	Sump pallets
Codice / Code	VPF-02
Fusti Drums	2 pcs
Capacità Capacity	220 lt.

Contentore olio usato
Waste oil tank

Codice / Code	EXOIL-300
Capacità /capacity	300 lt
Altezza/Height	1080 mm
∅	820 mm
Codice / Code	EXOIL-500
Capacità /capacity	500 lt
Altezza/Height	1240 mm
∅	960 mm



Contentore batterie esauste
Waste accumulator tank

Codice / Code	BT-300
Capacità /capacity	297Lt/300kg
Dim. int / Int. dim	940x640x500mm
Dimensioni /Dim.	1000x700x650mm



Recuperatore olio
Oil drainer recover

Codice / Code	3183
Capacità /capacity	10lt
Capacità recupero Recovery capacity	65lt
Pressione Pressure	0,5 bar
Altezza massima Max height	1400 mm
Dimensioni Dimensions	430x570x1200 mm
Peso/Weight	30 kg



Tanica olio esausto 10lt
10lt waste oil tank

Codice / Code	ECO-T10
Capacità /capacity	10lt
Dimensioni Dimensions	570x320x130 mm



Vasca olio esausto trasportabile
con ruote

36lt waste oil tank with wheels



36L

Codice / Code	ECO-T36
Capacità /capacity	36lt
Dimensioni Dimensions	570x370x280 mm



Tanica olio esausto 12lt

12lt waste oil tank

Codice / Code	ECO-T12
Capacità /capacity	12lt
Dimensioni Dimensions	570x370x135 mm



RAMP-4000



Codice / Code	RAMP-4000
Capacità /capacity	340 kg
Lunghezza/Length	2400 mm (aperto-open) 1200 mm (chiuso-closed)
Larghezza/Width	280 mm
Altezza bordo Edge height	50 mm
Peso/Weight	7 kg

Disponibile anche in versione colorata da abbinare al colore del proprio veicolo.

Colored version on demand to match the color of your own vehicle.





Cinghia di sicurezza Tie-down strap	
Codice / Code	TD-1B
Lunghezza/Length	1800 mm
Tenuta/Strength	500 kg



Cinghia di sicurezza Tie-down strap	
Codice / Code	R-1B
Lunghezza/Length	3600 mm
Tenuta/Strength	500 kg

MORSE PER FURGONI E TRAILER - WHEEL CLAMPS



Cinghia a cricchetto
Ratchet tie-down

Codice / Code	RTD-6
Lunghezza/Length	1800 mm
Tenuta/Strength	700 kg



Regolabile
Fully adjustable

Codice / Code	W-42/N
Azionamento/Action	Automatic
Apertura/Opening range	12"-21"
Dimensioni/Dimensions	36x65x36 cm
Peso/Weight	12 kg



Codice / Code	W-36 F
Azionamento/Action	Automatic
Lunghezza/Length	690 mm
Altezza/Height	430 mm
Peso/Weight	14 kg



Codice / Code	W-38 C
Azionamento/Action	Automatic
Lunghezza/Length	670 mm
Altezza/Height	430 mm
Peso/Weight	8 kg



Codice / Code	W-28 F
Azionamento/Action	Automatic
Apertura/Opening range	12"-21"
Peso/Weight	10 kg



Codice / Code	W-29 EB
Azionamento/Action	Automatic
Apertura/Opening range	12"-21"
Peso/Weight	10 kg

ATTREZZI PROFESSIONALI
PROFESSIONAL TOOLS

PULITORE FRENI E FRIZIONI BRAKES AND CLUTCH CLEANER

NEW
2026

Ideale per la pulizia di dischi, pastiglie freno e mo-tori. Grazie alla sua formulazione permette di eli-minare qualsiasi incrostazione di grasso e catrame, senza lasciare residui. Adatto anche come sgrassante generico di superfici metalliche. Ad evaporazione rapida. Non intacca gomma e plastica.

Ideal for cleaning brake discs, pads, and engines. Thanks to its formula, it removes any buildup of grease and tar without leaving residues. Also suitable as a general degreaser for metal surfaces. Fast-evaporating. Does not damage rubber or plastic.



Codice / Code	PF-10
Capacità /capacity	10lt

Codice / Code	PF-20
Capacità /capacity	20lt



Codice / Code	PF-900
Capacità /capacity	0,900lt



PF-10 = 71 bombolette/cans



Morsa professionale
120mm in acciaio
forgiato

120mm forged steel
professional vice

Codice / Code	BL-33721120
Apertura max/Max opening	150 mm
Lunghezza/Length	65 mm
Altezza/Height	156 mm
Peso/Weight	9 kg



Morsa in acciaio
125mm

125mm steel vice

Codice / Code	BL-33700125
Apertura max/Max opening	125 mm
Piano incudine/Anvil plane	100x80 mm
Peso/Weight	10,5 kg



Morsa universale
portatile

Universal portable
vice

Codice / Code	BL-3620
---------------	----------------



Protezioni magnetiche per
morsa banco

Magnetic soft jaws for
bench vice

Codice / Code	BL-33714125
---------------	--------------------



Vaschetta magnetica
tonda Ø150 mm

Magnetic tray Ø150 mm

Codice / Code	BL-487001
---------------	------------------



Vaschetta magnetica
rettangolare

Rectangular magnetic tray

Codice / Code	BL-487002
---------------	------------------



Vaschetta magnetica
tonda Ø150 mm

Magnetic tray Ø150
mm

Codice / Code	BL-815002
---------------	------------------



Guanti premium nitrilico
Resistenza eccezionale,
spessorato e puntinato
Premium nitrile gloves
Exceptional resistance,
thickened and dotted

Codice / Code	BL-30025003
TAGLIE/SIZE	S-M-L-XL-XXL



Lampada a led ricaricabile
con 3 testine intercambiabili

Codice / Code

Professional recharging led
lamp with 3 different heads

BL-KB400

Version	Torcia Torque	Led	Testa snodata Pivoting head
Angolo luce Light Edge	10°-80°	120°	20°-60°
Potenza/Power	3W	3W	3W
Flusso luminoso Lighting Power	250Lm	290Lm	90Lm
Autonomia Charging	2h	2h	2,5h

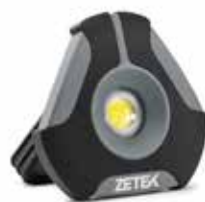

Faretto led con magnete
Potenza 12W
Flusso luminoso 1500Lm
Led lamp with magnet
Power 12W
Lightning power 1500Lm

Codice / Code

BL-KFL210



Pistola a caldo con
display digitale
50°-650°

Heat gun with
digital display
50°-650°

Codice / Code

BL-832002



Kit pinza per crimpare

Codice / Code

Crimping plier kit

BL-813001



Spelafili automatico
0,5-4mm

Automatic wire
stripper 0,5-4mm

Codice / Code

BL-4471180



Kit 160 pezzi connettori per
cavi elettrici

Codice / Code

160pcs insulated crimp
terminal assortment

BL-4822333



Kit 127 pezzi guaine
termorestringenti

Codice / Code

127pcs shrwking hose
assortment

BL-4822302



Set metrico maschi e filiere 110pezzi

110pcs combination top and die set

Codice / Code

BL-820016



Kit 8 pezzi estrattore viti spezzate

8pcs broken screw extractor set
3-6/6-8/8-11/11-14/14-18

Codice / Code

BL-32944008



Multichiave per asse ruote 3/8" 3/8" spindle tool

H17-H19-H22-H24

Codice / Code

BL-1642



Assortimento inserti filettati: M5x0,8, M6x1, M8x,25, M10x1,5, M12x1,75

Thread inserts set: M5x08, M6x1, M8x1,25, M10x1,5, M12x1,75

Codice / Code

BL-7998 8512



Contafiletti a 20 lame

20 blades metric screw pitch gauge

Codice / Code

BL-47010000



Multichiave in alluminio per asse ruote 3/8"

3/8" aluminium spindle tool

H17-H19-H22-H24

Codice / Code

BL-1622



Set filetti metrici di ricambio 12 pezzi
Metric thread insert refill set 12pcs

21706 M5x0,8
21708 M6x1
21709 M8x1,25
21710 M10x1,5
21711 M12x1,75

Codice / Code

BL-217...



Spessimetro combinato 0.03-1mm

0.001-0.040 inches feeler gauge dual reading

Codice / Code

BL-47002



Chiave a bussola poligonale per ruota posteriore Ducati

3/4" 12pts flank socket for Ducati rear wheel

Codice / Code

BL-24955



Kit installazione
guarnizioni forcelle

*Fork gasket
installation set*
35/36-39-41-43-45-
46/47-48-49/50-54

Codice / Code

BL-3650



Utensile
installazione
cuscinetti sterzo
*Steering bearings
installation tool set*
3x42 1x46 1x38 1x36
1x32

Codice / Code

BL-0340



Set estrattori
cuscinetti interni

*Engine bearing
puller set*
MM: 8-10-12-15-17-20-
25-30

Codice / Code

BL-0430



Strumento misurazione
livello olio forcelle

*Fork oil lever measuring
instrument*

Codice / Code

BL-3815



Utensile rimozione
cuscinetti sterzo 39-57 mm

*Head cup for steering
bearings 1.1-32"-1.17/32"*

Codice / Code

BL-0330



Kit montaggio
cuscinetti

*Bearing race and
seal driver set*
mm: 40-45-50-59-63-
65

Codice / Code

BL-7222912



Utensile montaggio
cuscinetti radiali

Race setting tool set

Codice / Code

BL-0310



Utensile rimozione
cuscinetti sterzo 26-39 mm

*Head cup for steering
bearings 1.17/32" 2.1/1/4"*

Codice / Code

BL-0320



Set 30 pezzi chiavi
per filtri olio
Ø65>108mm

*30pcs oil filter
wrenches set*
Ø65>108mm

Codice / Code

BL-6141691



Kit universale smagliatura, rivettatura catena

Universal heavy duty chain tool kit

Codice / Code

BL-7226152



Giraviti angolare per carburatore

Angle driver for carburator

Codice / Code

BL-6210



Attrezzo regolazione valvole
Tapper adjustment driver set

8mm - 1/8" - 9mm
10mm

Codice / Code

BL-7220544



Kit 11 pezzi chiave di bloccaggio universale

11pcs kit universal holder

Codice / Code

BL-7224744



Estrattore per volano

Flywheel puller

M14x1.5R - M16x1.5R
M18x1.5R - M24x1.5R
M10x1.25R - M27x1.0L

Codice / Code

BL-2768



Disco graduato fasatura motori Ducati

Timing degree gauge for Ducati engines

Codice / Code

BL-5925



Spazzola pulisci catena

Motorcycle chain brush

Codice / Code

BL-1370



Blocca volano e pulegge

Flywheel holder

Codice / Code

BL-2210



Utensile separazione pistoncini

Disc brake adjuster

Codice / Code

BL-7220651



Chiave a settore
regolabile

*Adjustable hook
wrench*
25-70 mm

Codice / Code

BL-1630



Uncino per
trazionamento
molle
Spring hook tool

Codice / Code

BL-47814

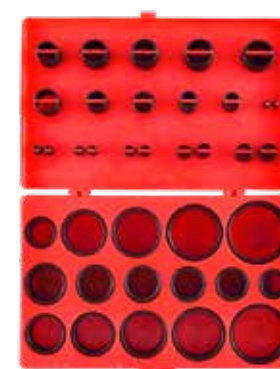

Assortimento o-ring
metrici 419 pezzi

*419pcs o-ring
assortment*
3.00x1,5 mm >
50x3,5 mm

Codice / Code

BL-4822323



Pinza torcifilo
acciaio

*Lock wire twisting
plier*
9"

Codice / Code

BL-4020



Assortimento anelli elastici
285 pezzi

285pcs circlip assortment

Codice / Code

BL-4822306



Assortimento coppiglie
555 pezzi

*555pcs splin pin
assortment*

Codice / Code

BL-4822308



Filo inossidabile in
bobina da 450gr.

*450gr. look wire
spools*

Codice / Code

BL-4030

BL-4035

mm

0,6

0,8



Assortimento anelli elastici
(seeger) 300 pezzi

*300pcs external circlip
assortment*

Codice / Code

BL-4822301



Calibro digitale doppia
misurazione

*Stainless steel digital
caliper dual reading*

Codice / Code

BL-47010



Attrezzo spurgo olio freni professionale

Professional brake bleeder set

Codice / Code

BL-7223530



Caraffe tubo flessibile, scala metrica e US
Flexible spout jug metric ad US scale

Codice / Code	Lt
BL-39203001	1
BL-39203002	2
BL-39203005	5



Specchietto per ispezioni telescopico

Telescopic inspection mirror

Codice / Code

BL-482011



Serbatoio ausiliario per motori a iniezione 3,6lt

3,6lt auxiliary fuel tank for injection engines

Codice / Code

BL-7224777



Imbuto in PVC con tubo flessibile Ø180mm

Ø180mm PVC flexible funnel

Codice / Code

BL-56141



Magnete flessibile 400mm

Flexible magnet pick-up 400mm

Codice / Code

BL-4820207



Serbatoio ausiliario benzina 1lt

1lt auxiliary fuel bottle

Codice / Code

BL-7223068



Le immagini a colori sono puramente indicative e possono non corrispondere alle tonalità reali dei prodotti. I disegni sono indicative alle informazioni ed illustrano l'impiego dei prodotti.

Bike-Lift Europe Srl si riserva la possibilità di cambiare, modificare od eliminare prodotti da questo catalogo senza preavviso.

© **2025-2026 Bike-Lift Europe Srl.**

Tutti i diritti riservati. È vietata qualsiasi forma di riproduzione anche parziale.

The color pictures are merely indicative and may not match the exact product color or true tone.

The designs refers to the information and explain the use of the products.

Bike-Lift Europe Srl reserves the right to change, modify or eliminate products in this catalogue without prior notice.

© **2025-2026 Bike-Lift Europe Srl.**

All rights reserved. The reproduction even partial is forbidden.



DIM SPORT

DIM SPORT

ARTBOX

ARTBOX

ARTBOX

like-lift

like-lift



Via Don Milani, 40/42 Sanguinaro di Fontanellato (PR) Italy | Tel. +39.0521.827091 - Fax. 0521.827064
info@bikelifteurope.it - www.bikelifteurope.it